

01 DOG PARK ENLARGED PLAN

SCALE: 1"=10'-0"

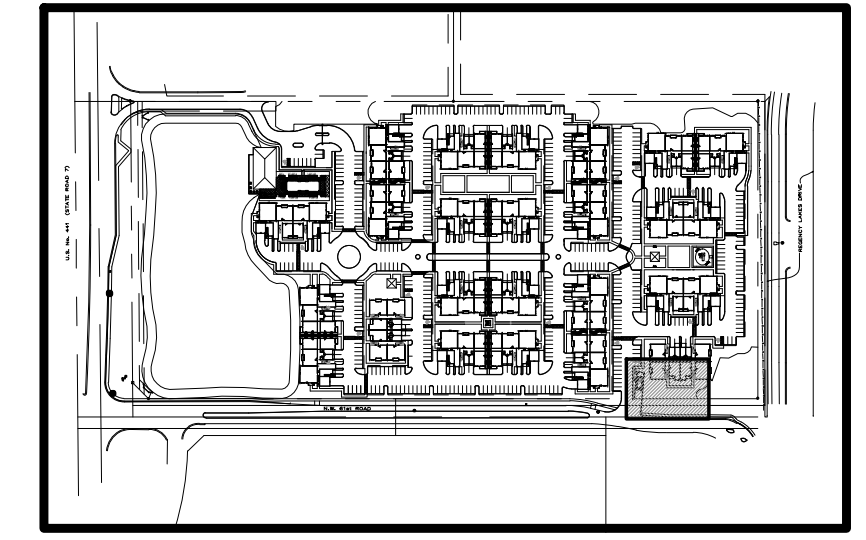

KEYMAP

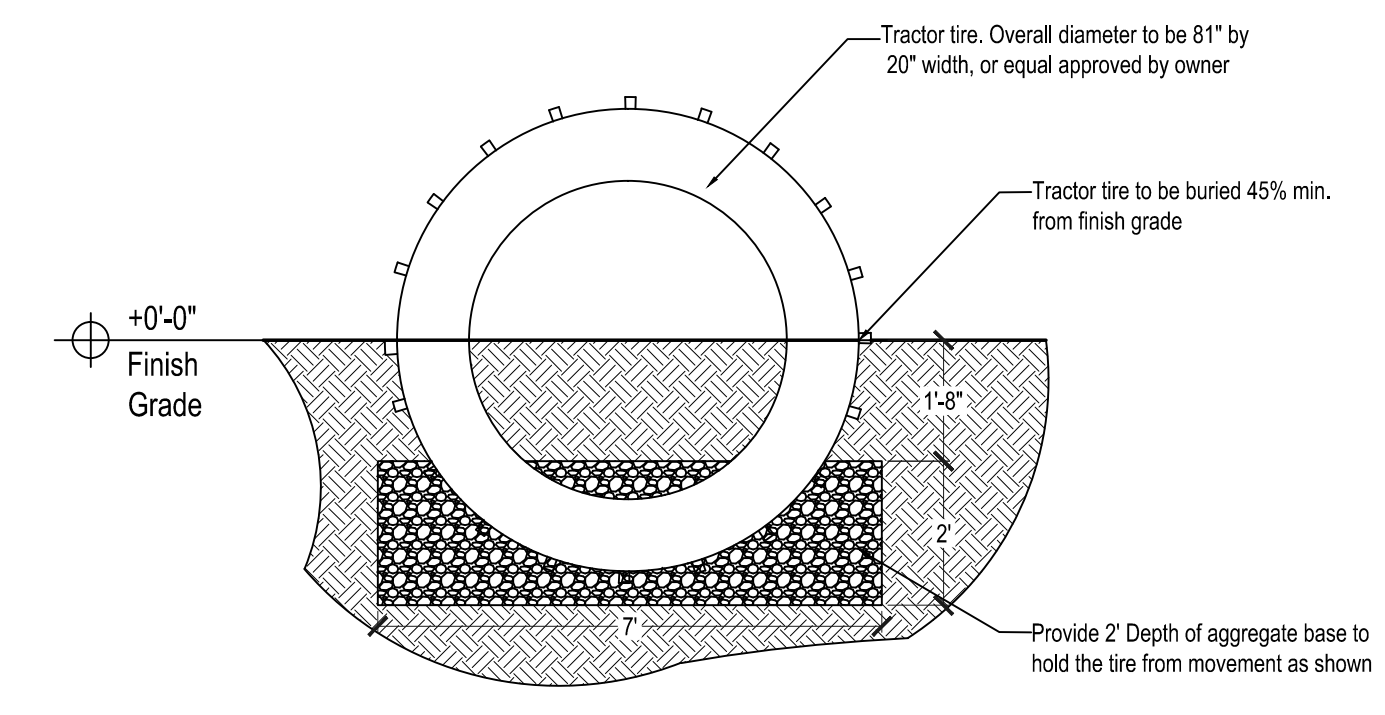

02 BURIED TRACTOR TIRE DETAIL

SCALE: 3/8" = 1'-0"

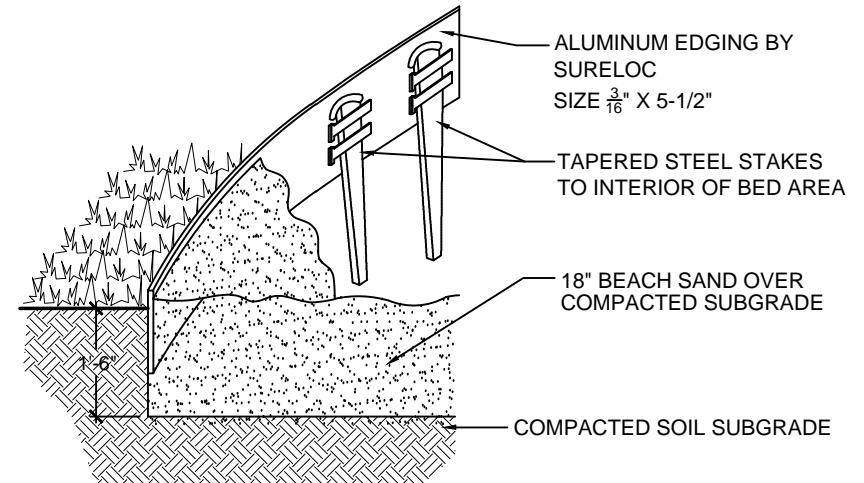

03 SAND BEACH DETAIL

SCALE: 3/8" = 1'-0"

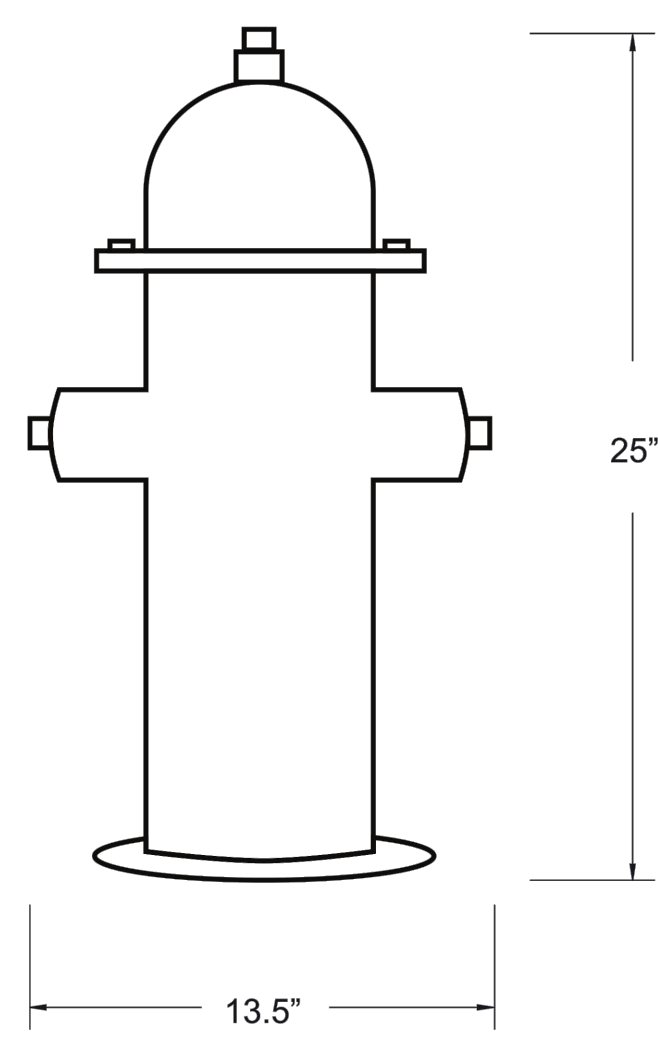

04 DOG FIRE HYDRANT DETAIL

SCALE: NOT TO SCALE

FIRE HYDRANT

DL-965-P

ABOUT
The most popular spot in the park! The Fire Hydrant is resistant to urine and creates a fun social hang-out! Surface mounted

KEY FEATURES
COLORS
- DL-965-P : ●

PRODUCT DIMENSIONS
- DIMENSIONS (L x H) : 13.5" x 25"
- WEIGHT (lbs) : 41 lbs

SHIPPING DIMENSIONS
- SHIPPING (L x W x H) Small: 48" x 24" x 48"
- MOUNT TYPE : Surface Mount

www.LivinTheDogLife.com

www.LivinTheDogLife.com
SU-2014
DOGGIE WATER STATION
DRINK, WASH, COOL

SPECIFICATIONS
ITEM DL-9000-66-SW
Color: Green
Product Dimensions: 32" H x 6-5/8" Dia. x 19-5/8" W 32 lbs.
Materials: Urine Resistant
Mount Type: Surface Mount, Plumbing Required



05 PET FOUNTAIN AND METERED SHOWER

SCALE: NOT TO SCALE

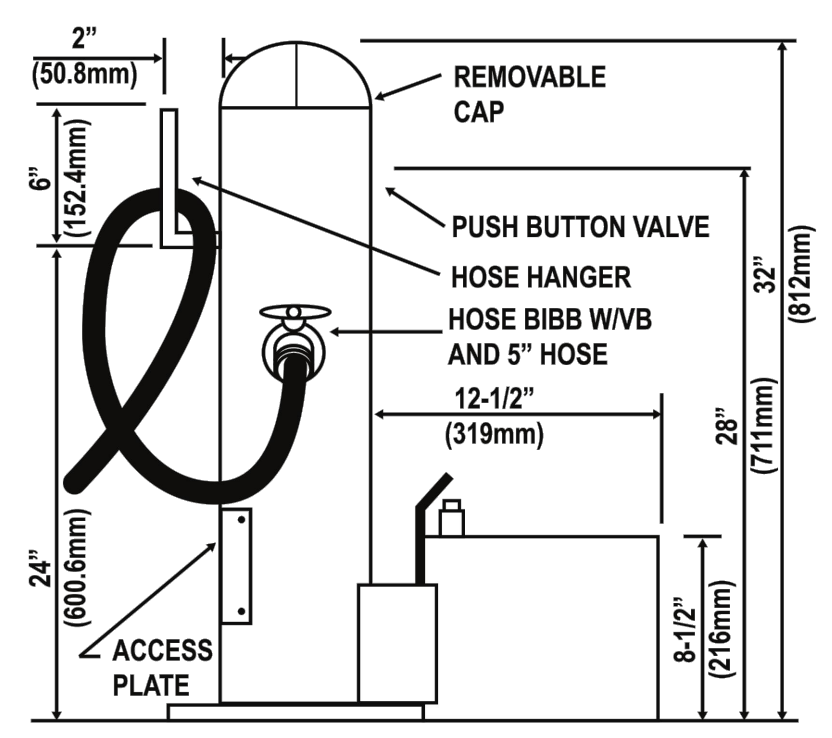

THE MANUFACTURER TO MEET ACCESSIBILITY REQUIREMENTS.

PLAN SYMBOL
DOGIPOT ALUMINUM PET STATION, (COLOR: Natural/DL-490-N FROM LIVIN THE DOG LIFE, OR EQUAL APPROVED)

SPECIFICATIONS
PRODUCT DIMENSIONS: 9.25" L X 12.75" W X 67" H 22 LBS.
MATERIALS: URINE RESISTANT
MOUNT TYPE: IN-GROUND MOUNT, SURFACE MOUNT

06 PET COMFORT STATION DETAIL

SCALE: NOT TO SCALE