

D CURB DETAIL

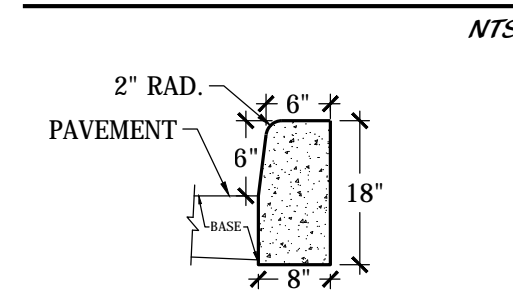

F CURB DETAIL

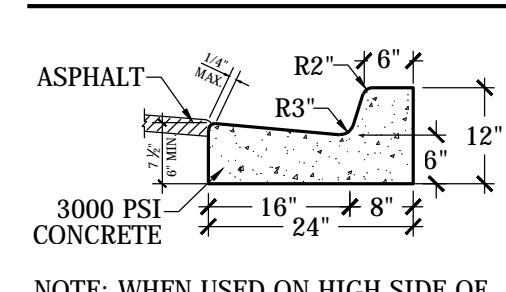

NOTE: WHEN USED ON HIGH SIDE OF ROADWAYS, THE CROSS SLOPE OF THE CUTTER SHALL MATCH THE SLOPE OF ADJACENT PAVEMENT AND THICKNESS OF THE LIP SHALL BE 6 INCHES.

HANDICAP SIGN & SYMBOL DETAILS

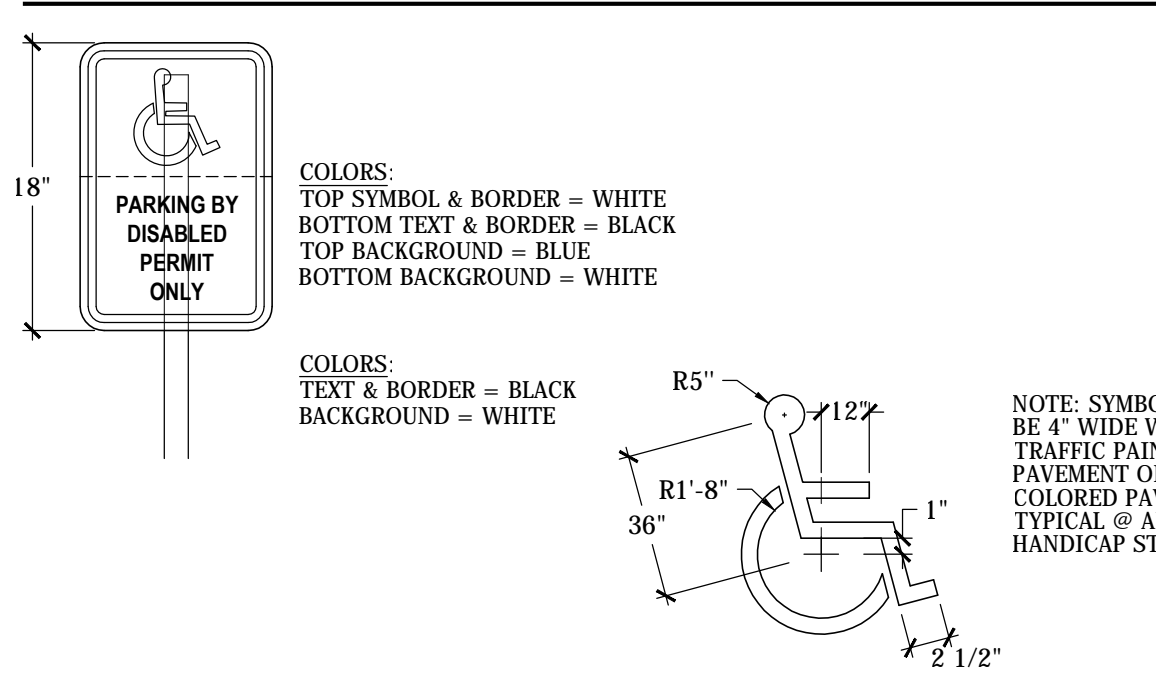

HANDICAP RAMP DETAIL

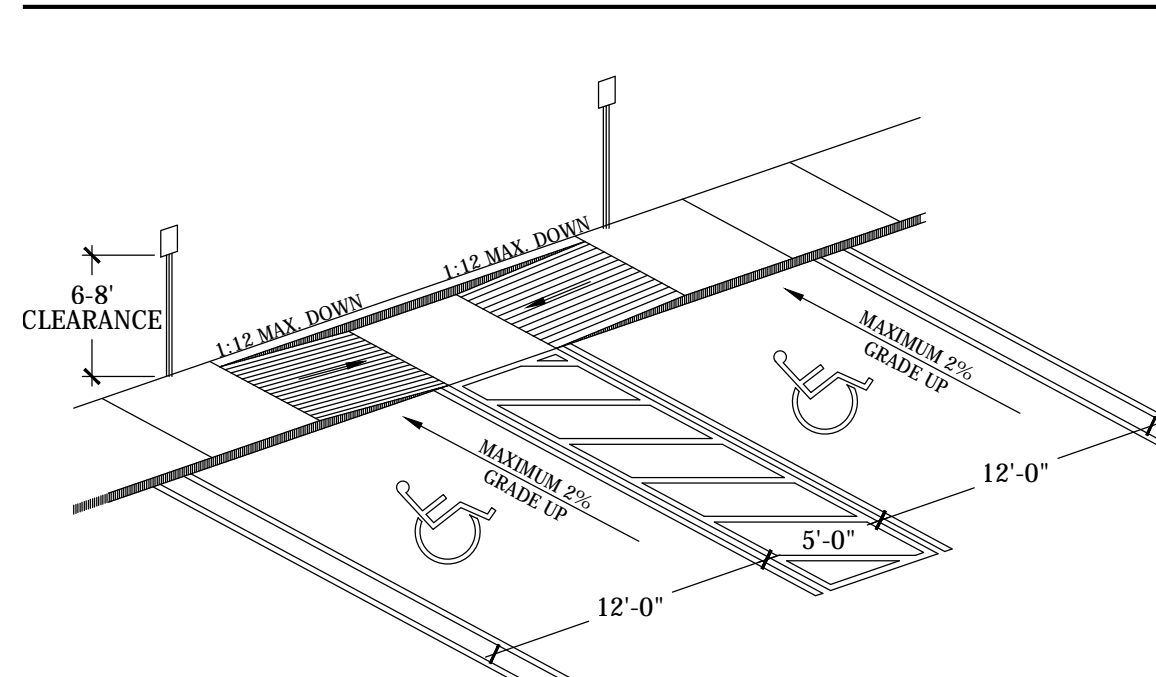

NOTE: IN THIS APPLICATION RAMPS CAN BE SEPARATED AND SIDEWALK CAN BE FLUSH ACROSS ALL HC SPACES
NOTE: HCR#3-MOD MEANS ONLY 1 RAMP BUILT TO REQUIRED SIDE OF SIDEWALK. OR RAMPS SEP. TO ENDS OF HC SPACES

HANDICAP PARKING DETAIL

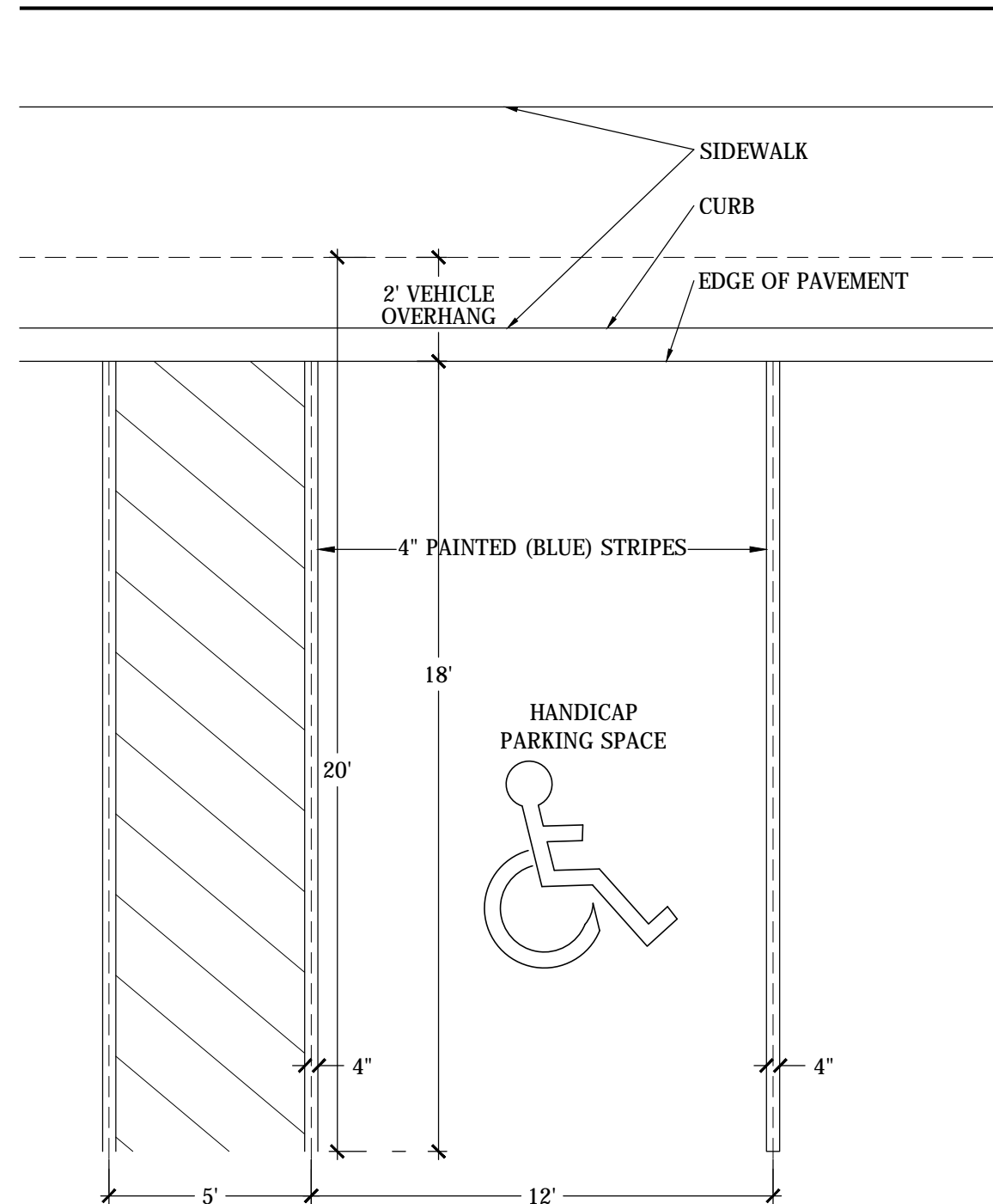

TRANSFORMER DETAIL

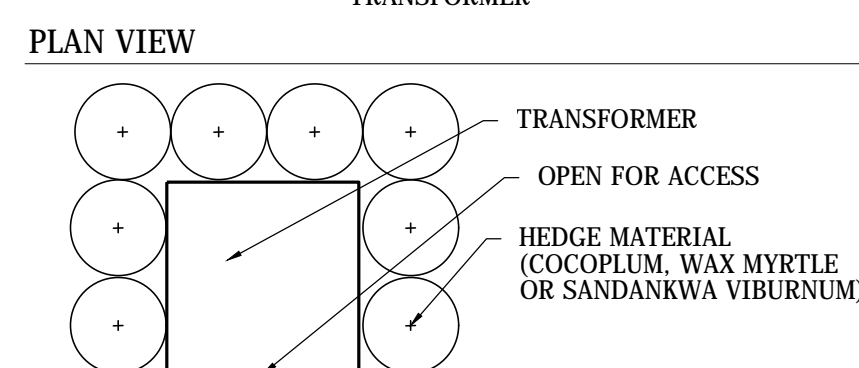
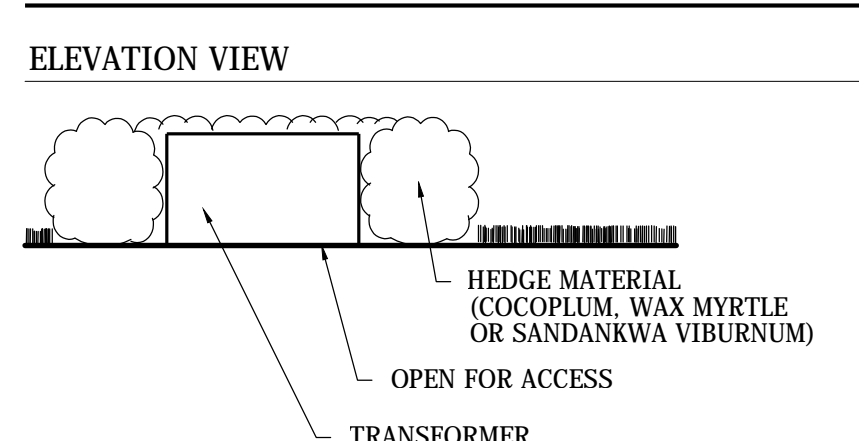

VALLEY CURB DETAIL

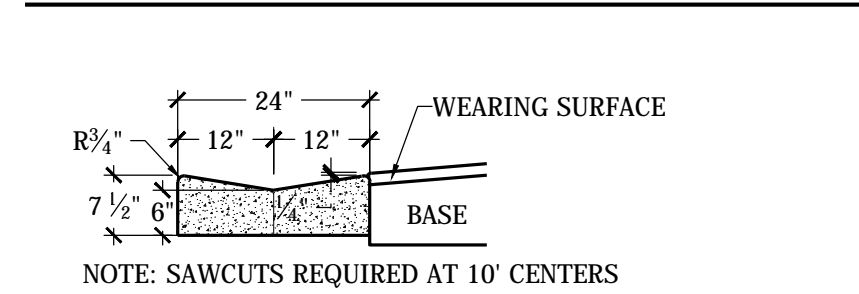

BIKE RACK DETAIL

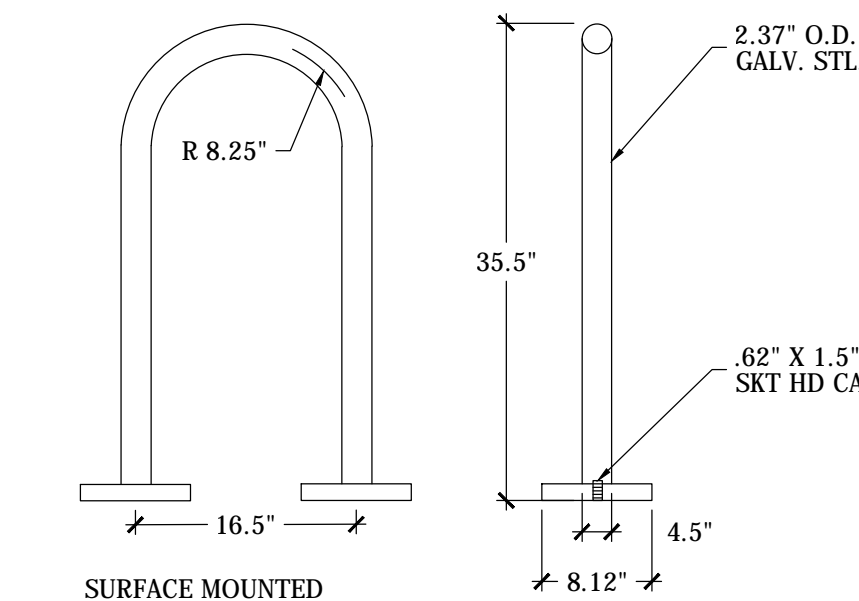
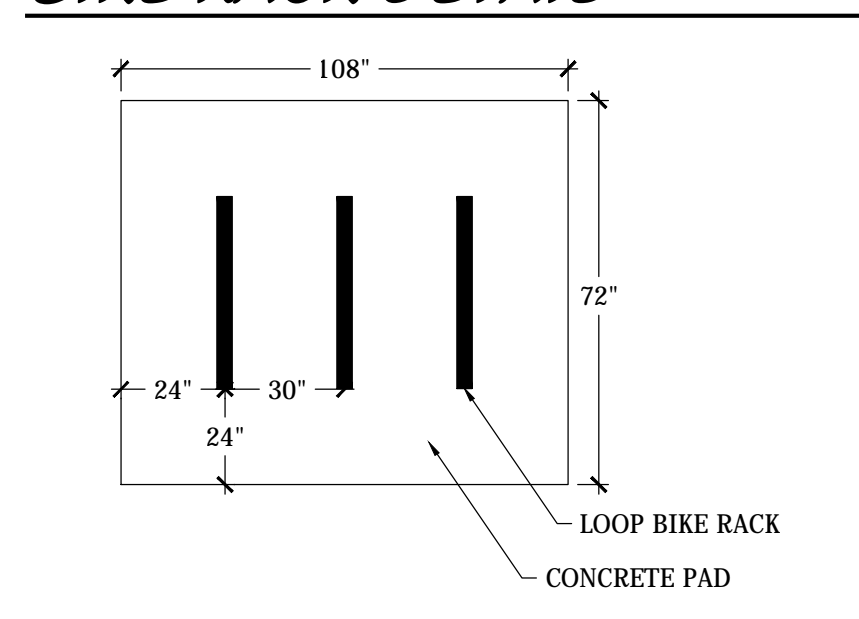

PARKING LOT LIGHT DETAIL

Cree Edge™ Series
LED Area Flood Luminaire

Product Description
The Cree Edge™ Series has a slim, low profile design. Its rugged cast aluminum housing utilizes advanced technology for superior performance. The Cree Edge™ Series is available in a variety of sizes and configurations to meet your specific lighting needs.

Performance Summary

Model	Power (W)	Beam Angle	Height (ft)	Beam Diameter (ft)
ARE-EDR-4MB/4MP-R3	4000	30°	18	12
ARE-EDR-4MB/4MP-R3	4000	30°	20	14
ARE-EDR-4MB/4MP-R3	4000	30°	24	18
ARE-EDR-4MB/4MP-R3	4000	30°	30	24
ARE-EDR-4MB/4MP-R3	4000	30°	36	30
ARE-EDR-4MB/4MP-R3	4000	30°	42	36
ARE-EDR-4MB/4MP-R3	4000	30°	48	42
ARE-EDR-4MB/4MP-R3	4000	30°	54	48
ARE-EDR-4MB/4MP-R3	4000	30°	60	54
ARE-EDR-4MB/4MP-R3	4000	30°	66	60
ARE-EDR-4MB/4MP-R3	4000	30°	72	66
ARE-EDR-4MB/4MP-R3	4000	30°	78	72
ARE-EDR-4MB/4MP-R3	4000	30°	84	78
ARE-EDR-4MB/4MP-R3	4000	30°	90	84
ARE-EDR-4MB/4MP-R3	4000	30°	96	90
ARE-EDR-4MB/4MP-R3	4000	30°	102	96
ARE-EDR-4MB/4MP-R3	4000	30°	108	102
ARE-EDR-4MB/4MP-R3	4000	30°	114	108
ARE-EDR-4MB/4MP-R3	4000	30°	120	114
ARE-EDR-4MB/4MP-R3	4000	30°	126	120
ARE-EDR-4MB/4MP-R3	4000	30°	132	126
ARE-EDR-4MB/4MP-R3	4000	30°	138	132
ARE-EDR-4MB/4MP-R3	4000	30°	144	138
ARE-EDR-4MB/4MP-R3	4000	30°	150	144
ARE-EDR-4MB/4MP-R3	4000	30°	156	150
ARE-EDR-4MB/4MP-R3	4000	30°	162	156
ARE-EDR-4MB/4MP-R3	4000	30°	168	162
ARE-EDR-4MB/4MP-R3	4000	30°	174	168
ARE-EDR-4MB/4MP-R3	4000	30°	180	174
ARE-EDR-4MB/4MP-R3	4000	30°	186	180
ARE-EDR-4MB/4MP-R3	4000	30°	192	186
ARE-EDR-4MB/4MP-R3	4000	30°	198	192
ARE-EDR-4MB/4MP-R3	4000	30°	204	198
ARE-EDR-4MB/4MP-R3	4000	30°	210	204
ARE-EDR-4MB/4MP-R3	4000	30°	216	210
ARE-EDR-4MB/4MP-R3	4000	30°	222	216
ARE-EDR-4MB/4MP-R3	4000	30°	228	222
ARE-EDR-4MB/4MP-R3	4000	30°	234	228
ARE-EDR-4MB/4MP-R3	4000	30°	240	234
ARE-EDR-4MB/4MP-R3	4000	30°	246	240
ARE-EDR-4MB/4MP-R3	4000	30°	252	246
ARE-EDR-4MB/4MP-R3	4000	30°	258	252
ARE-EDR-4MB/4MP-R3	4000	30°	264	258
ARE-EDR-4MB/4MP-R3	4000	30°	270	264
ARE-EDR-4MB/4MP-R3	4000	30°	276	270
ARE-EDR-4MB/4MP-R3	4000	30°	282	276
ARE-EDR-4MB/4MP-R3	4000	30°	288	282
ARE-EDR-4MB/4MP-R3	4000	30°	294	288
ARE-EDR-4MB/4MP-R3	4000	30°	300	294
ARE-EDR-4MB/4MP-R3	4000	30°	306	300
ARE-EDR-4MB/4MP-R3	4000	30°	312	306
ARE-EDR-4MB/4MP-R3	4000	30°	318	312
ARE-EDR-4MB/4MP-R3	4000	30°	324	318
ARE-EDR-4MB/4MP-R3	4000	30°	330	324
ARE-EDR-4MB/4MP-R3	4000	30°	336	330
ARE-EDR-4MB/4MP-R3	4000	30°	342	336
ARE-EDR-4MB/4MP-R3	4000	30°	348	342
ARE-EDR-4MB/4MP-R3	4000	30°	354	348
ARE-EDR-4MB/4MP-R3	4000	30°	360	354
ARE-EDR-4MB/4MP-R3	4000	30°	366	360
ARE-EDR-4MB/4MP-R3	4000	30°	372	366
ARE-EDR-4MB/4MP-R3	4000	30°	378	372
ARE-EDR-4MB/4MP-R3	4000	30°	384	378
ARE-EDR-4MB/4MP-R3	4000	30°	390	384
ARE-EDR-4MB/4MP-R3	4000	30°	396	390
ARE-EDR-4MB/4MP-R3	4000	30°	402	396
ARE-EDR-4MB/4MP-R3	4000	30°	408	402
ARE-EDR-4MB/4MP-R3	4000	30°	414	408
ARE-EDR-4MB/4MP-R3	4000	30°	420	414
ARE-EDR-4MB/4MP-R3	4000	30°	426	420
ARE-EDR-4MB/4MP-R3	4000	30°	432	426
ARE-EDR-4MB/4MP-R3	4000	30°	438	432
ARE-EDR-4MB/4MP-R3	4000	30°	444	438
ARE-EDR-4MB/4MP-R3	4000	30°	450	444
ARE-EDR-4MB/4MP-R3	4000	30°	456	450
ARE-EDR-4MB/4MP-R3	4000	30°	462	456
ARE-EDR-4MB/4MP-R3	4000	30°	468	462
ARE-EDR-4MB/4MP-R3	4000	30°	474	468
ARE-EDR-4MB/4MP-R3	4000	30°	480	474
ARE-EDR-4MB/4MP-R3	4000	30°	486	480
ARE-EDR-4MB/4MP-R3	4000	30°	492	486
ARE-EDR-4MB/4MP-R3	4000	30°	498	492
ARE-EDR-4MB/4MP-R3	4000	30°	504	498
ARE-EDR-4MB/4MP-R3	4000	30°	510	504
ARE-EDR-4MB/4MP-R3	4000	30°	516	510
ARE-EDR-4MB/4MP-R3	4000	30°	522	516
ARE-EDR-4MB/4MP-R3	4000	30°	528	522
ARE-EDR-4MB/4MP-R3	4000	30°	534	528
ARE-EDR-4MB/4MP-R3	4000	30°	540	534
ARE-EDR-4MB/4MP-R3	4000	30°	546	540
ARE-EDR-4MB/4MP-R3	4000	30°	552	546
ARE-EDR-4MB/4MP-R3	4000	30°	558	552
ARE-EDR-4MB/4MP-R3	4000	30°	564	558
ARE-EDR-4MB/4MP-R3	4000	30°	570	564
ARE-EDR-4MB/4MP-R3	4000	30°	576	570
ARE-EDR-4MB/4MP-R3	4000	30°	582	576
ARE-EDR-4MB/4MP-R3	4000	30°	588	582
ARE-EDR-4MB/4MP-R3	4000	30°	594	588
ARE-EDR-4MB/4MP-R3	4000	30°	600	594
ARE-EDR-4MB/4MP-R3	4000	30°	606	600
ARE-EDR-4MB/4MP-R3	4000	30°	612	606
ARE-EDR-4MB/4MP-R3	4000	30°	618	612
ARE-EDR-4MB/4MP-R3	4000	30°	624	618
ARE-EDR-4MB/4MP-R3	4000	30°	630	624
ARE-EDR-4MB/4MP-R3	4000	30°	636	630
ARE-EDR-4MB/4MP-R3	4000	30°	642	636
ARE-EDR-4MB/4MP-R3	4000	30°	648	642
ARE-EDR-4MB/4MP-R3	4000	30°	654	648
ARE-EDR-4MB/4MP-R3	4000	30°	660	654
ARE-EDR-4MB/4MP-R3	4000	30°	666	660
ARE-EDR-4MB/4MP-R3	4000	30°	672	666
ARE-EDR-4MB/4MP-R3	4000	30°	678	672
ARE-EDR-4MB/4MP-R3	4000	30°	684	678
ARE-EDR-4MB/4MP-R3	4000	30°	690	684
ARE-EDR-4MB/4MP-R3	4000	30°	696	690
ARE-EDR-4MB/4MP-R3	4000	30°	702	696
ARE-EDR-4MB/4MP-R3	4000	30°	708	702
ARE-EDR-4MB/4MP-R3	4000	30°	714	708
ARE-EDR-4MB/4MP-R3	4000	30°	720	714
ARE-EDR-4MB/4MP-R3	4000	30°	726	720
ARE-EDR-4MB/4MP-R3	4000	30°	732	726
ARE-EDR-4MB/4MP-R3	4000	30°	738	732
ARE-EDR-4MB/4MP-R3	4000	30°	744	738
ARE-EDR-4MB/4MP-R3	4000	30°	750	744
ARE-EDR-4MB/4MP-R3	4000	30°	756	750
ARE-EDR-4MB/4MP-R3	4000	30°	762	756
ARE-EDR-4MB/4MP-R3	4000	30°	768	762
ARE-EDR-4MB/4MP-R3	4000	30°	774	768
ARE-EDR-4MB/4MP-R3	4000	30°	780	774
ARE-EDR-4MB/4MP-R3	4000	30°	786	780
ARE-EDR-4MB/4MP-R3	4000	30°	792	786
ARE-EDR-4MB/4MP-R3	4000	30°	798	792
ARE-EDR-4MB/4MP-R3	4000	30°	804	798
ARE-EDR-4MB/4MP-R3	4000	30°	810	804
ARE-EDR-4MB/4MP-R3	4000	30°	816	810
ARE-EDR-4MB/4MP-R3	4000	30°	822	816
ARE-EDR-4MB/4MP-R3	4000	30°	828	822
ARE-EDR-4MB/4MP-R3	4000	30°	834	828
ARE-EDR-4MB/4MP-R3	4000	30°	840	834
ARE-EDR-4MB/4MP-R3	4000	30°	846	840
ARE-EDR-4MB/4MP-R3	4000	30°	852	846
ARE-EDR-4MB/4MP-R3	4000	30°	858	852
ARE-EDR-4MB/4MP-R3	4000	30°	864	858
ARE-EDR-4MB/4MP-R3	4000	30°	870	864
ARE-EDR-4MB/4MP-R3	4000	30°	876	870
ARE-EDR-4MB/4MP-R3	4000	30°	882	876
ARE-EDR-4MB/4MP-R3	4000	30°	888	882
ARE-EDR-4MB/4MP-R3	4000	30°	894	888
ARE-EDR-4MB/4MP-R3	4000	30°	900	894
ARE-EDR-4MB/4MP-R3	4000	30°	906	900
ARE-EDR-4MB/4MP-R3	4000	30°	912	906
ARE-EDR-4MB/4MP-R3	4000	30°	918	912
ARE-EDR-4MB/4MP-R3	4000	30°	924	918
ARE-EDR-4MB/4MP-R3	4000	30°	930	924
ARE-EDR-4MB/4MP-R3	4000	30°	936	930
ARE-EDR-4MB/4MP-R3	4000	30°	942	936
ARE-EDR-4MB/4MP-R3	4000	30°	948	942
ARE-EDR-4MB/4MP-R3	4000	30°	954	948
ARE-EDR-4MB/4MP-R3	4000	30°	960	954
ARE-EDR-4MB/4MP-R3	4000	30°	966	960
ARE-EDR-4MB/4MP-R3	4000	30°	972	966
ARE-EDR-4MB/4MP-R3	4000	30°	978	972
ARE-EDR-4MB/4MP-R3	4000	30°	984	978
ARE-EDR-4MB/4MP-R3	4000	30°	990	984
ARE-EDR-4MB/4MP-R3	4000	30°	996	990
ARE-EDR-4MB/4MP-R3	4000	30°	1002	996

TYPICAL PARKING DETAIL

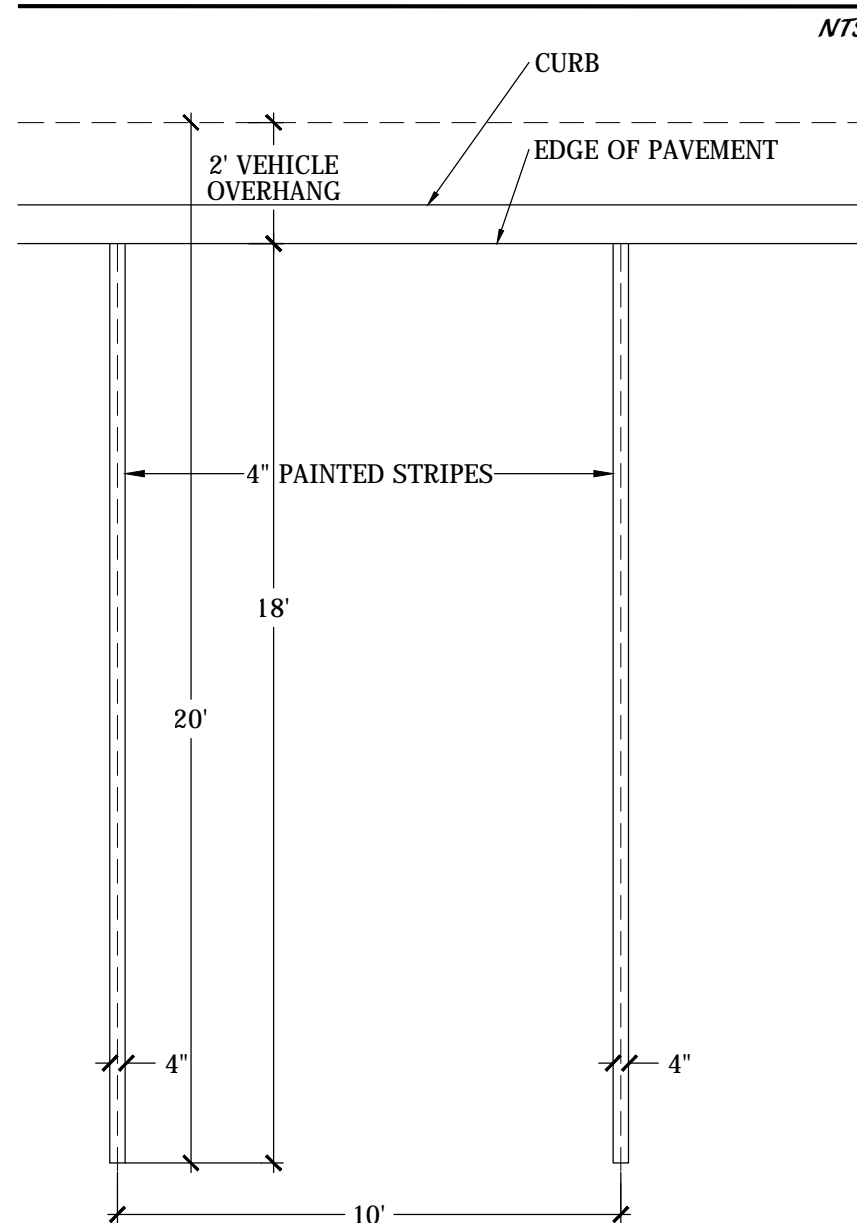

6' PVC FENCE DETAIL



BUTTERFLY BENCH DETAIL

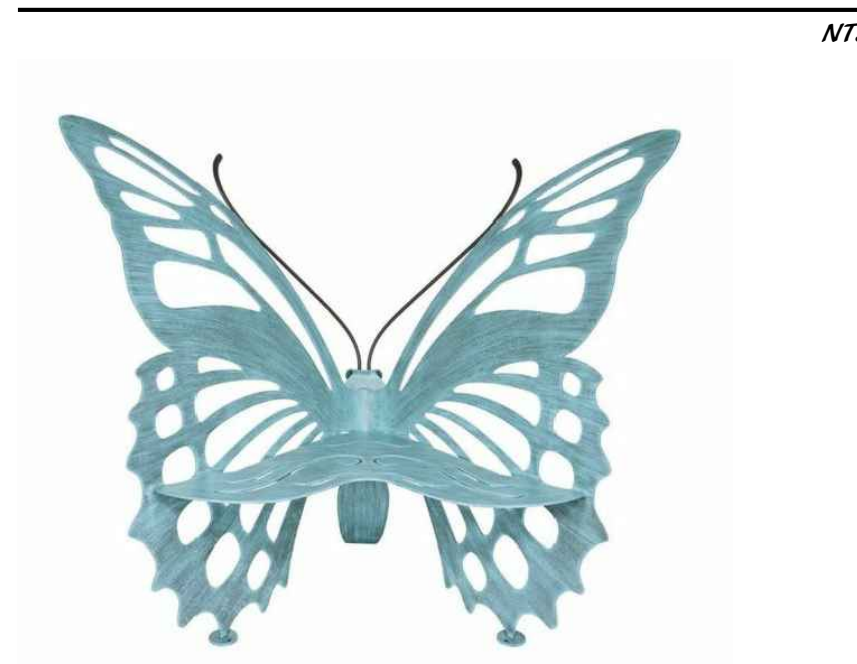

TYPICAL BENCH DETAIL

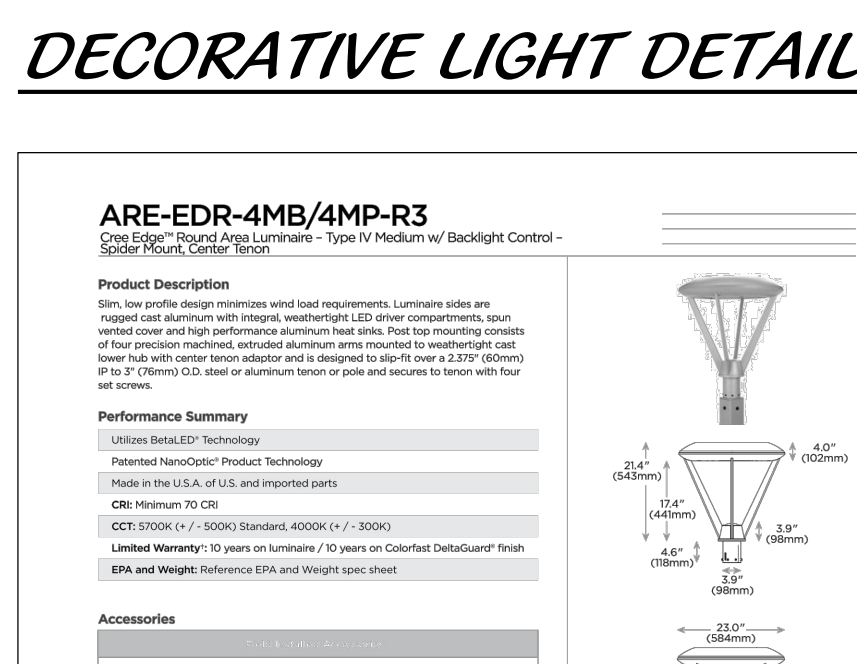

ARE-EDR-4MB/4MP-R3
Cree Edge™ Flood Area Luminaire - Type IV Medium w/ Backlight Control - 30° Flood, 4000K

Product Description
The Cree Edge™ Series has a slim, low profile design. Its rugged cast aluminum housing utilizes advanced technology for superior