

City of Coconut Creek InterOffice Memorandum

To: Site Plan File - PZ - 06010002

Date: July 28, 2009

From: Heidi Solano
Planner

Subject: El Dorado Tenant Signage

The Development Review Committee has accepted the following to be included within the approved site plan file. Due to the nature of the request and the negligible impacts associated with the change, no additional review is required. This memo shall serve as formal acceptance of the changes identified herein and will be archived as follows;

- 1) Planning Department's site plan approval file PZ – 06010002
- 2) Digital archive file;

S:\GIS\GIS\DevServices\Planning\ScannedSitePlans\SawgrassExchangePlat\El
Dorado Site Plan 1-11-06

Requested Change:

The original site plan included signage standards and specifications. The specifications dictated that all tenant signs were to be individually lit channel letters of a block style lettering (Avante Garde Bold). Letters were to be lit using 6500 snow white neon for all tenant signs except the El Dorado sign, which is to be lit using red neon. Specifications went on to say that all letters were to be internally lighted with neon and have no exposed neon. Also, all letters were to have red faces and duronatic (bronze) sides.

At the request of the property owner, standards will now specify that all tenant wall signs be individual aluminum reverse channel letters with red face and red returns. The red color to be used on face and returns of letters shall be #42212 Scarlett Red as manufactured by Mathews or the equivalent of this color. In addition, to accommodate lighting which is more energy efficient, sign specifications will be changed so that letters will be back-lit by white LED lights rather than snow white neon. The change from channel letter to reverse channel letter does not apply to the El Dorado furniture store which will continue to use red illuminated channel letters.

Consistent with the approved site plan, the sign standards concerning brightness remain in effect, that is, "Illuminated and other lighting effects shall not create a nuisance to adjacent property or create a traffic hazard". Standards and specifications concerning letter style, number of signs, size and logos, as detailed on the approved site plan, also remain in effect.

enc: sample sign specification for El Dorado tenant

cc: Scott Stoudenmire, Deputy Director
Liz Aguiar, Development Review Supervisor
Jim Hetzel, MainStreet Project Coordinator
Natacha Josiah, Zoning Inspector

Y:\Development Services\HSolano\Documents\PROJECTS IN REVIEW\El Dorado

20 FT. STORE FRONT

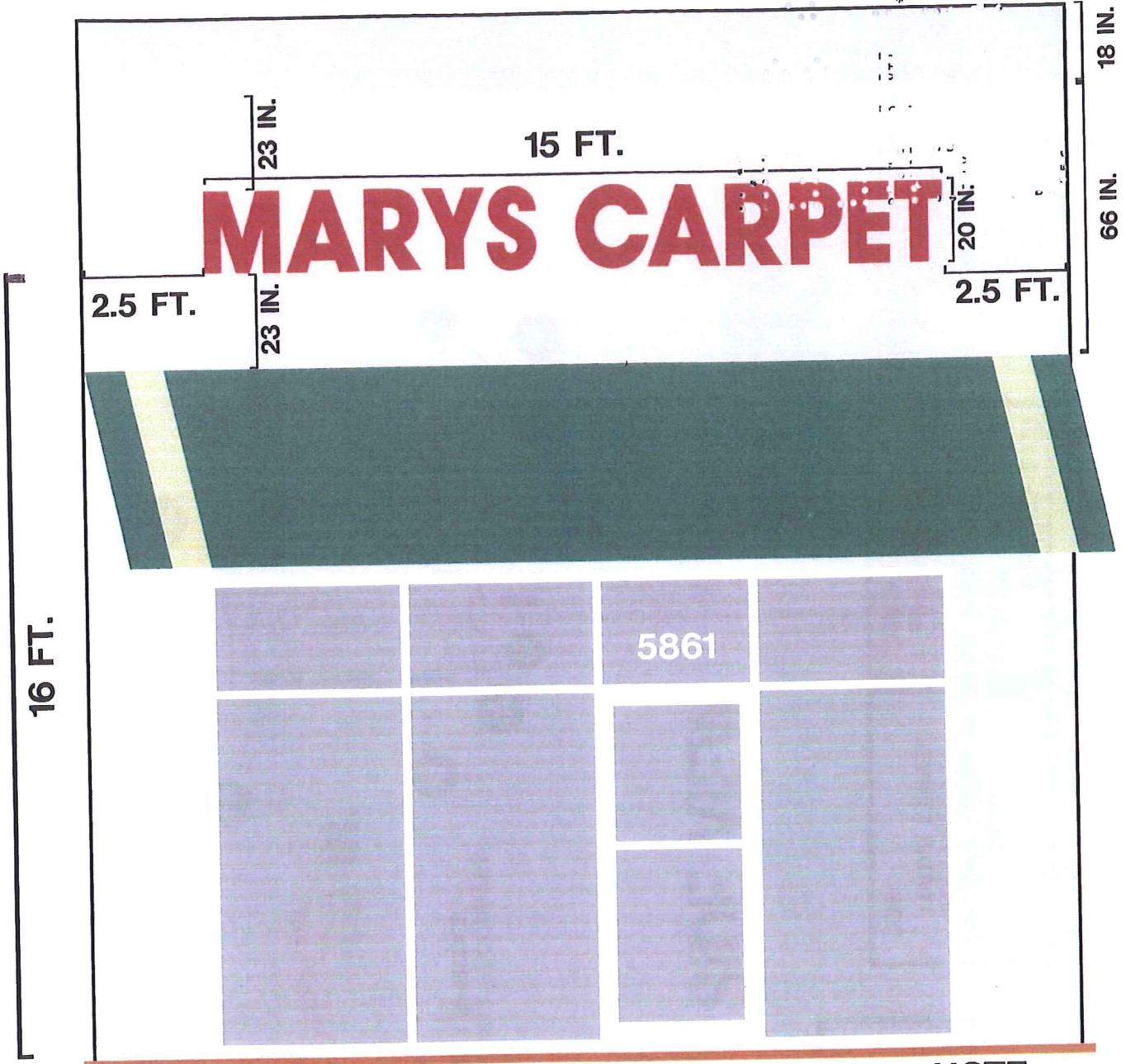

SIGN AREA
25 SQ. FT.

20 FT. STORE FRONT

NOTE

15 FT. SIGN IS 75 % OF
20 FT. STORE FRONT

<p>JOB: MARYS CARPET 5861 LYONS RD. COCONUT CREEK, FL. 33073</p>	<p>CONTRACTOR: J. FELDMAN SIGNS 3911 S.W. 12 CT. FT. LAUDERDALE, FL. 33312 ES 0000431 954-581-3928</p>
---	---

- A. ALUMINUM REVERSE CHANNEL
SIZE: 20 IN. LETTER COLOR: RED
- D. 1/2 IN. LIQUID TIGHT
- E. POWER SUPPLY CAN
- F. MOUNTING BOLTS
SIZE: 1/4 IN. X 2 IN. TAPCONS
MINIMUM: 4 PER LETTER
- G. 120 VOLT DISCONNECT
1 ON POWER SUPPLY CAN
NEC 600-2
1 TOGGLE ON FRONT WALL
NEC 600-2
- H. 12 VOLT LED'S: COLOR WHITE BI-MODES
- I. 120 VOLT POWER SUPPLY 12 VOLT SECONDARY
SIZE: (2) SINGLE CHANNEL
- K. WALL TYPE: CBS

20 IN. *100% 1542*

**SIGN AREA
25 SQ. FT.**

SIDE VIEW

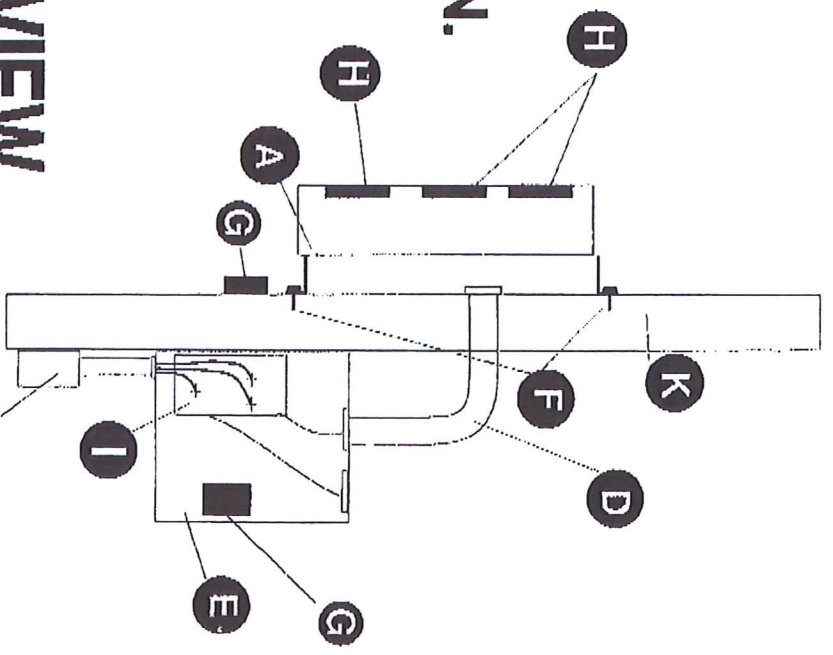

EXISTING 120 V SUPPLY (#12 THHN)
FROM CIRCUIT BREAKER PANEL BOX
THRU TIME CLOCK TO SIGN JUNCTION
BOX TO TRANSFORMER
20 AMP. CIR. BRK. CIRCUIT #
NEC 600-21

NOTE:
ALL ELECTRICAL COMPONENTS
ARE UL LISTED, SIGN GROUNDED
ACCORDING TO NEC 250

JOB:
MARYS CARPET
5861 LYONS RD.
COCONUT CREEK, FL.
33073

CONTRACTOR:
J. FELDMAN SIGNS
3911 S.W. 12 CT.
FT. LAUDERDALE FL.
ES0000431 33312
954-581-3928

GOVERNING CODE: 2007 FLORIDA BUILDING CODE WITH 3 SEC. GUST & ASCE 7-05 USING
V = 140MPH, EXPOSURE 'C', 1.077 SOLID SIGN METHOD
2 OCT 13 11:49 AM
ENGINEERING AGK, L.L.C
DON ARPIN M.S.P.E.
4920 N DIXIE HWY.
STRUCTURAL ONLY P.E. 28585
FT. LAUDERDALE, FL, 33334
TEL. 954-772-8945
COA # 26073

THIS ENGINEER HAS NOT VISITED THE JOBSITE. DESIGN IS BASED ON CONTRACTOR SUPPLIED DATA. IF ANY FIELD CONDITIONS THE SPECIFIED HEREIN, THIS ENGINEER SHALL BE NOTIFIED

VALID FOR (1)
JAMES M. VENTURA
REGISTERED PROFESSIONAL ENGINEER
NO. 12000
DATE: 08/20/13