

Date	Revisions	Appr. by	Date	Revised	Scale	N.T.S.	Desg.	F308	Fig.	308
------	-----------	----------	------	---------	-------	--------	-------	------	------	-----

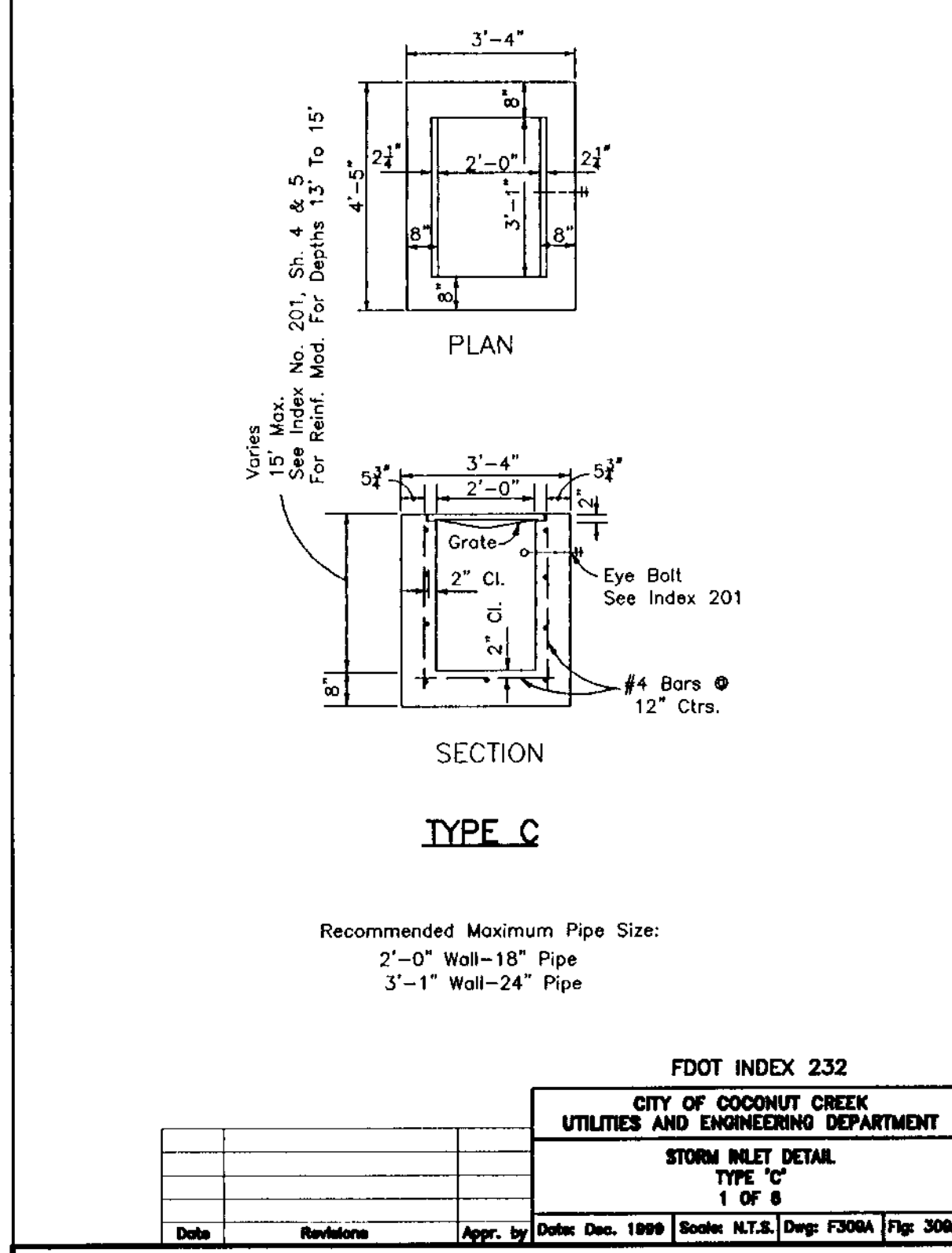

Date	Revisions	Appr. by	Date	Revised	Scale	N.T.S.	Desg.	F309A	Fig.	309A
------	-----------	----------	------	---------	-------	--------	-------	-------	------	------

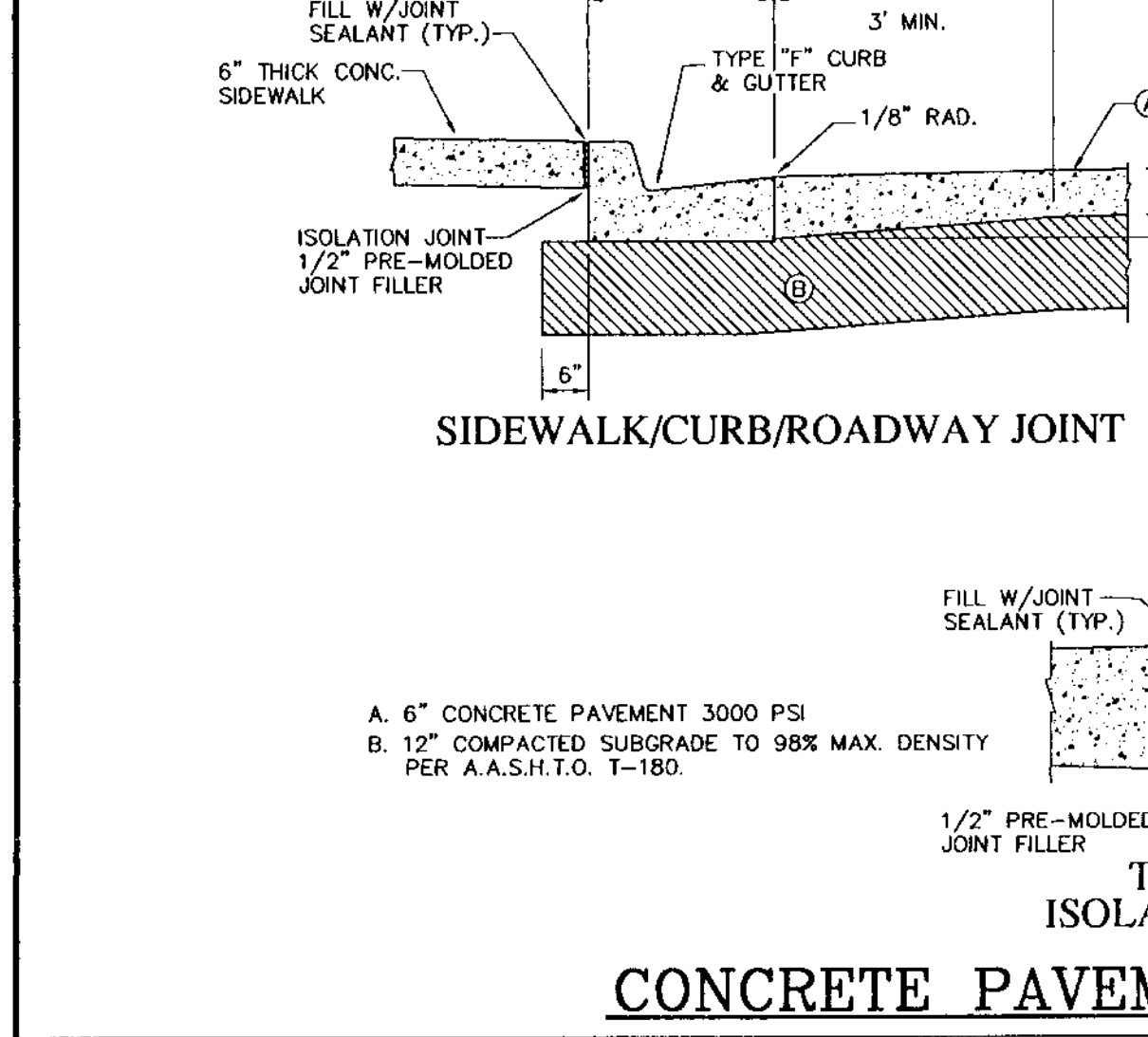

Date	Revisions	Appr. by	Date	Revised	Scale	N.T.S.	Desg.	F310	Fig.	310
------	-----------	----------	------	---------	-------	--------	-------	------	------	-----

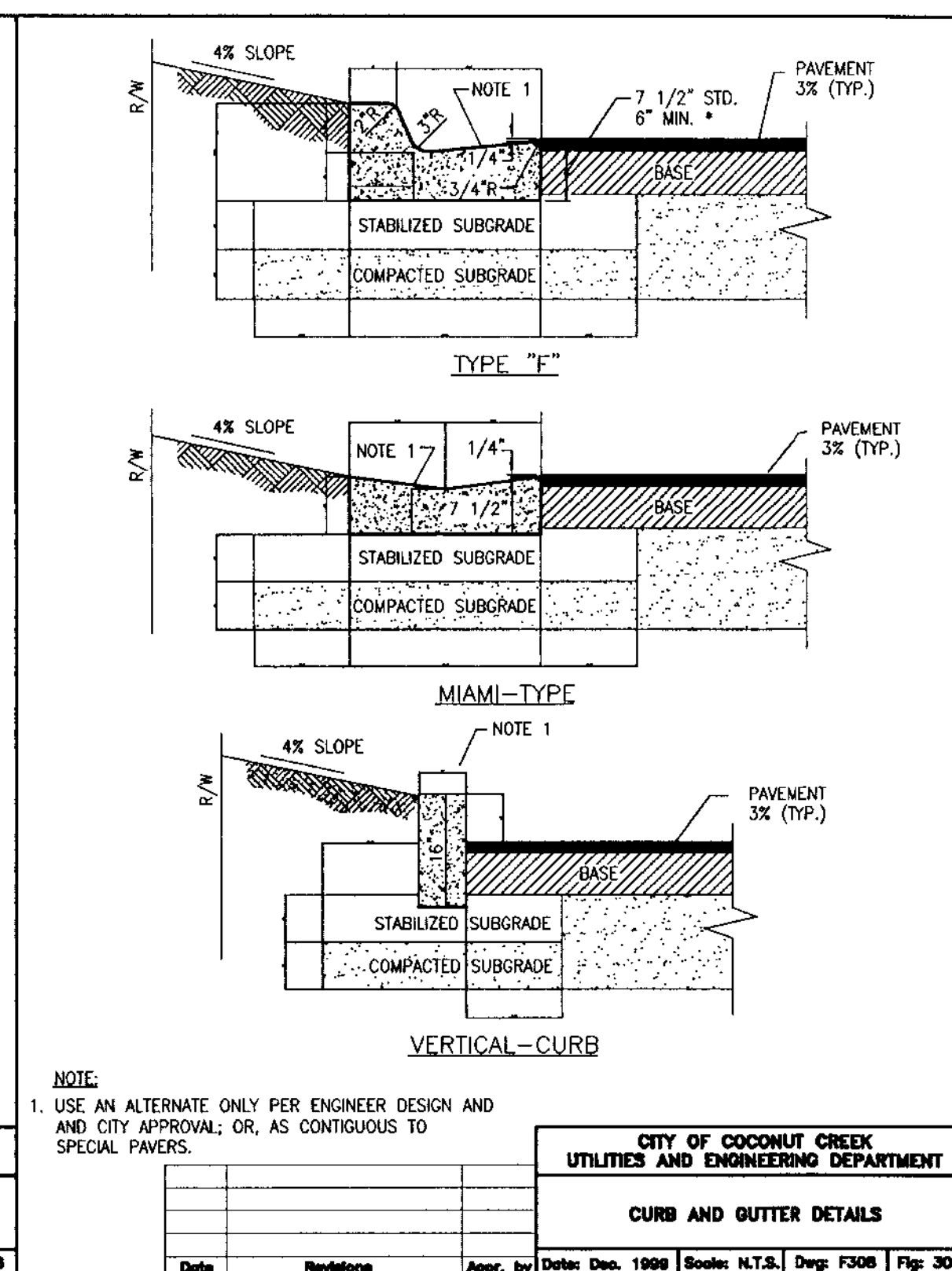

Date	Revisions	Appr. by	Date	Revised	Scale	N.T.S.	Desg.	F308	Fig.	308
------	-----------	----------	------	---------	-------	--------	-------	------	------	-----

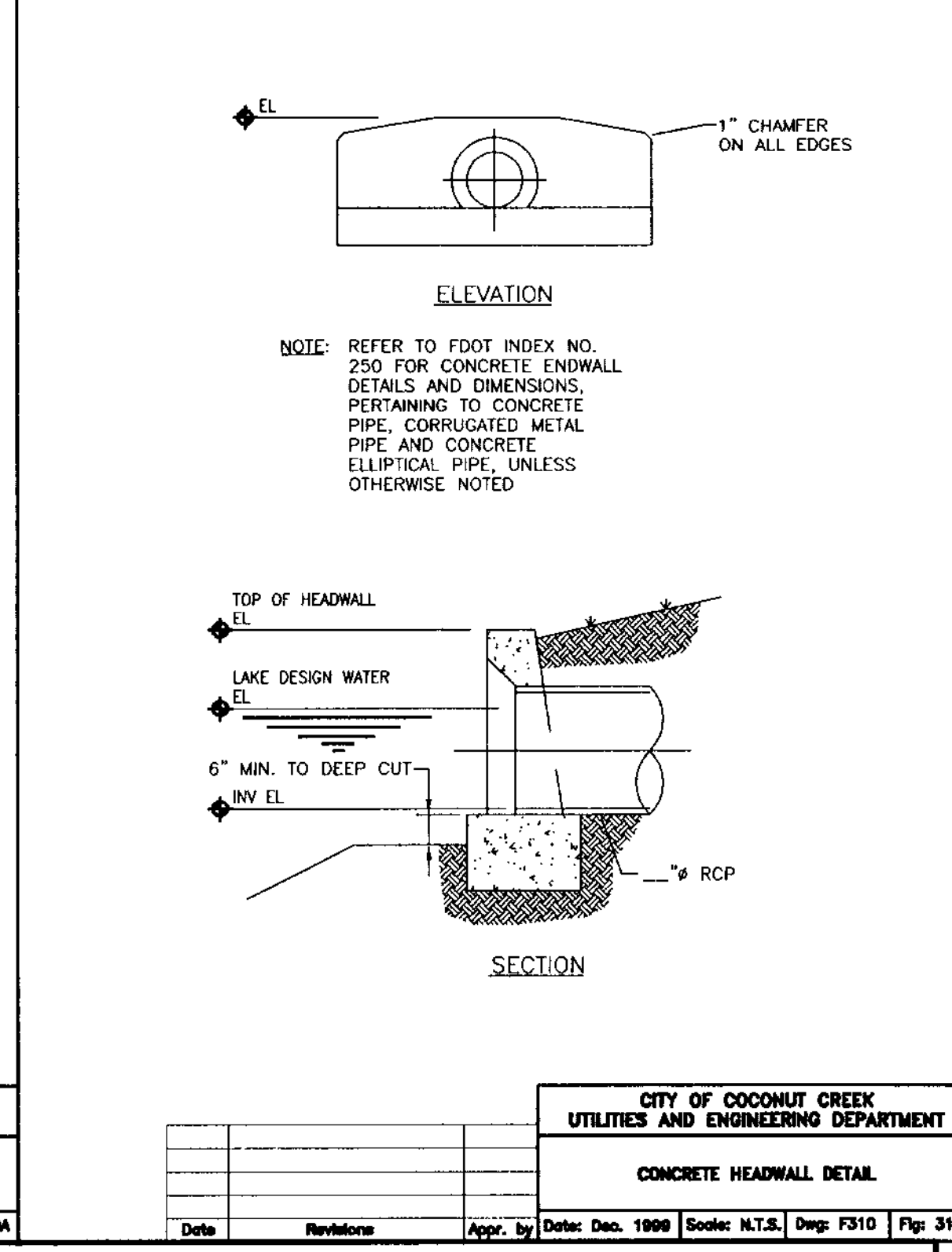

Date	Revisions	Appr. by	Date	Revised	Scale	N.T.S.	Desg.	F310	Fig.	310
------	-----------	----------	------	---------	-------	--------	-------	------	------	-----

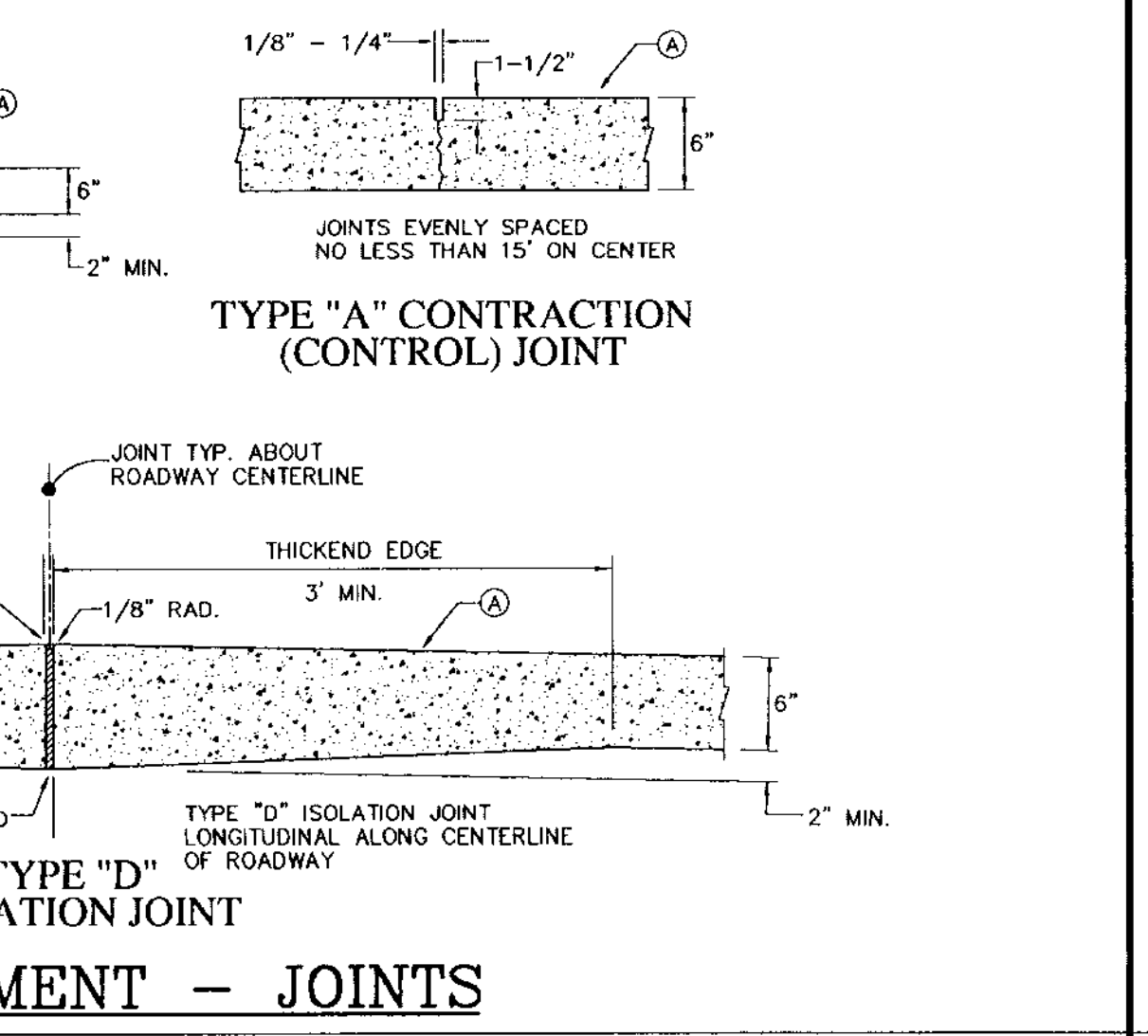

Date	Revisions	Appr. by	Date	Revised	Scale	N.T.S.	Desg.	F313	Fig.	313
------	-----------	----------	------	---------	-------	--------	-------	------	------	-----

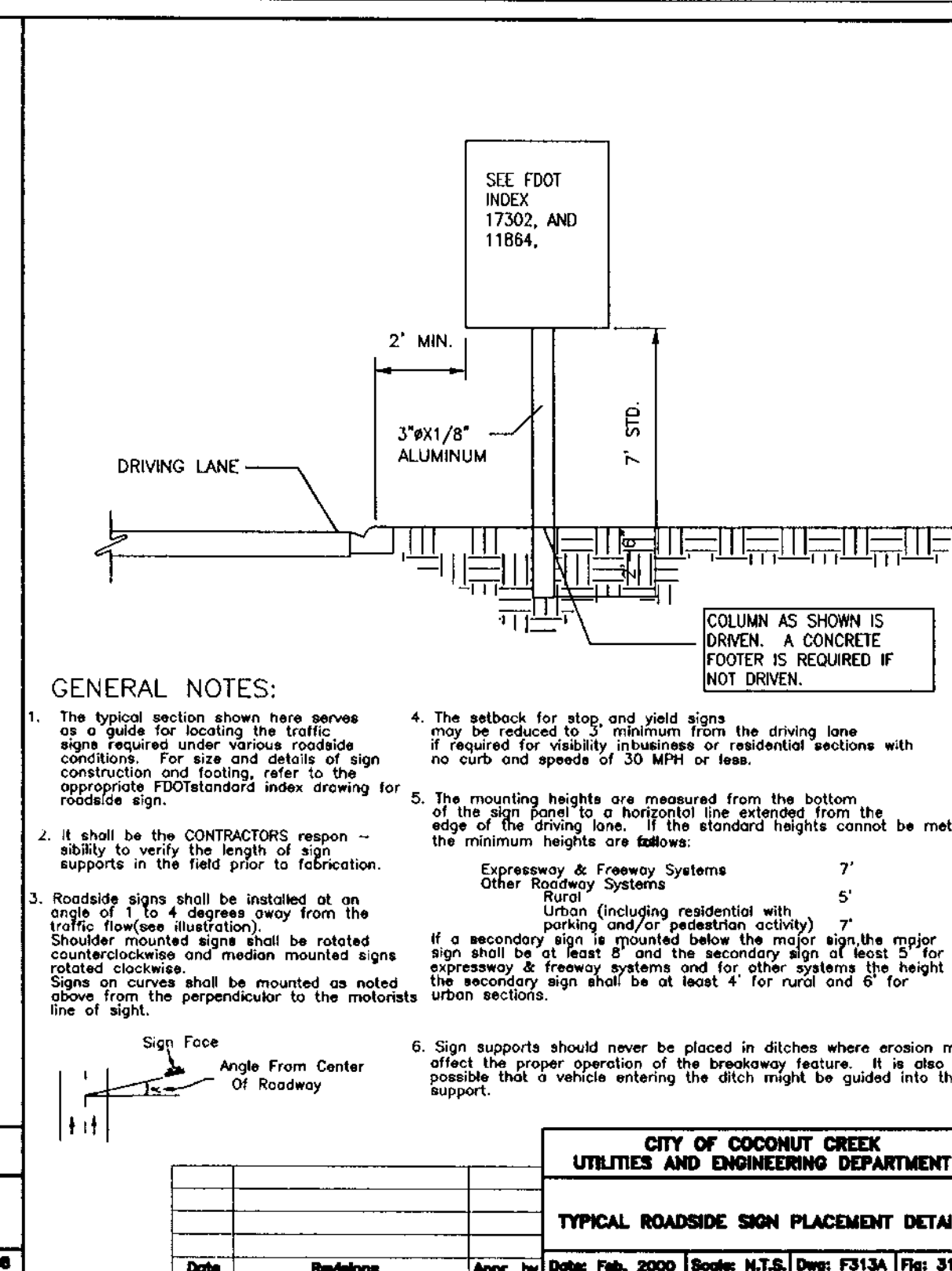

Date	Revisions	Appr. by	Date	Revised	Scale	N.T.S.	Desg.	F313A	Fig.	313A
------	-----------	----------	------	---------	-------	--------	-------	-------	------	------

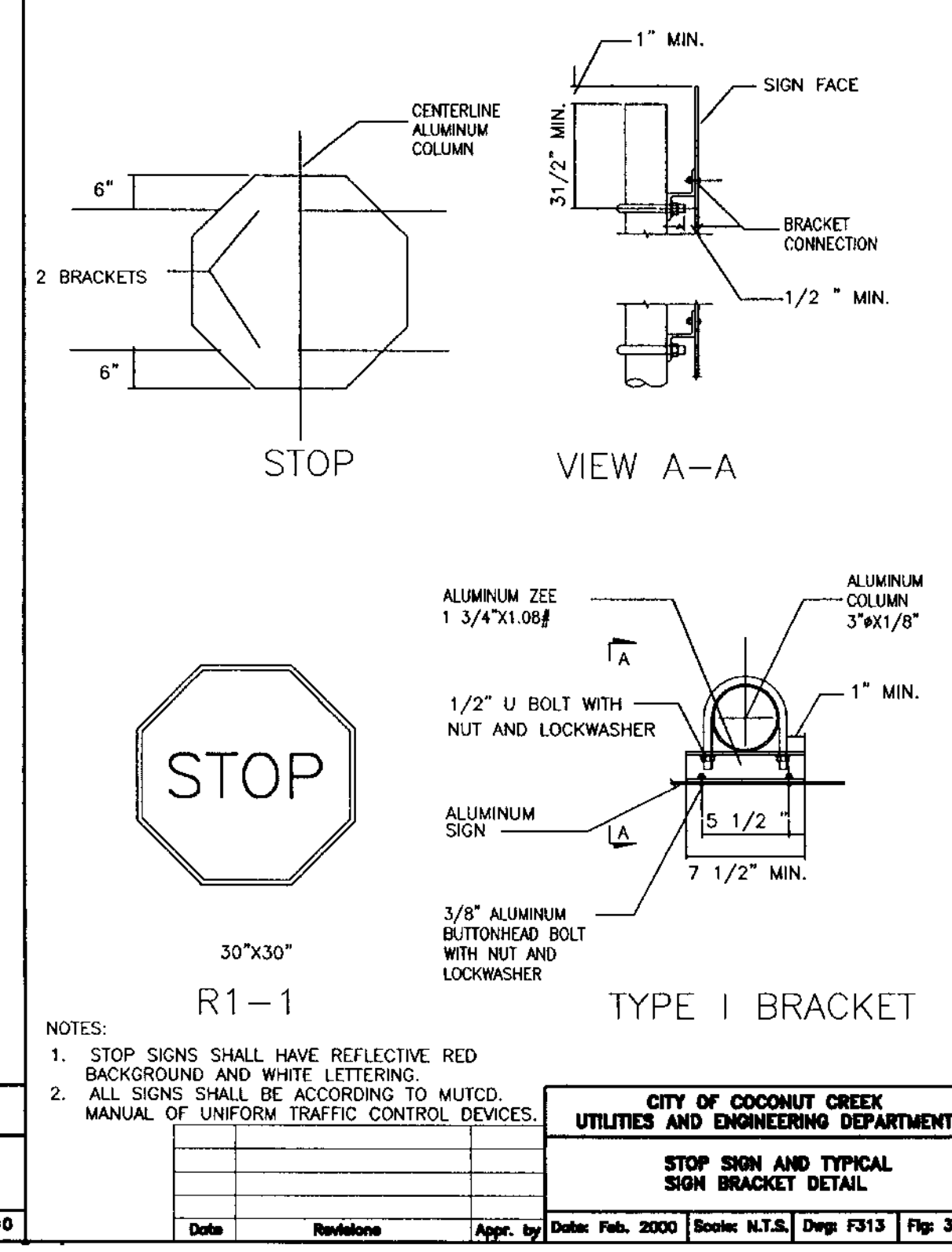

Date	Revisions	Appr. by	Date	Revised	Scale	N.T.S.	Desg.	F313	Fig.	313
------	-----------	----------	------	---------	-------	--------	-------	------	------	-----

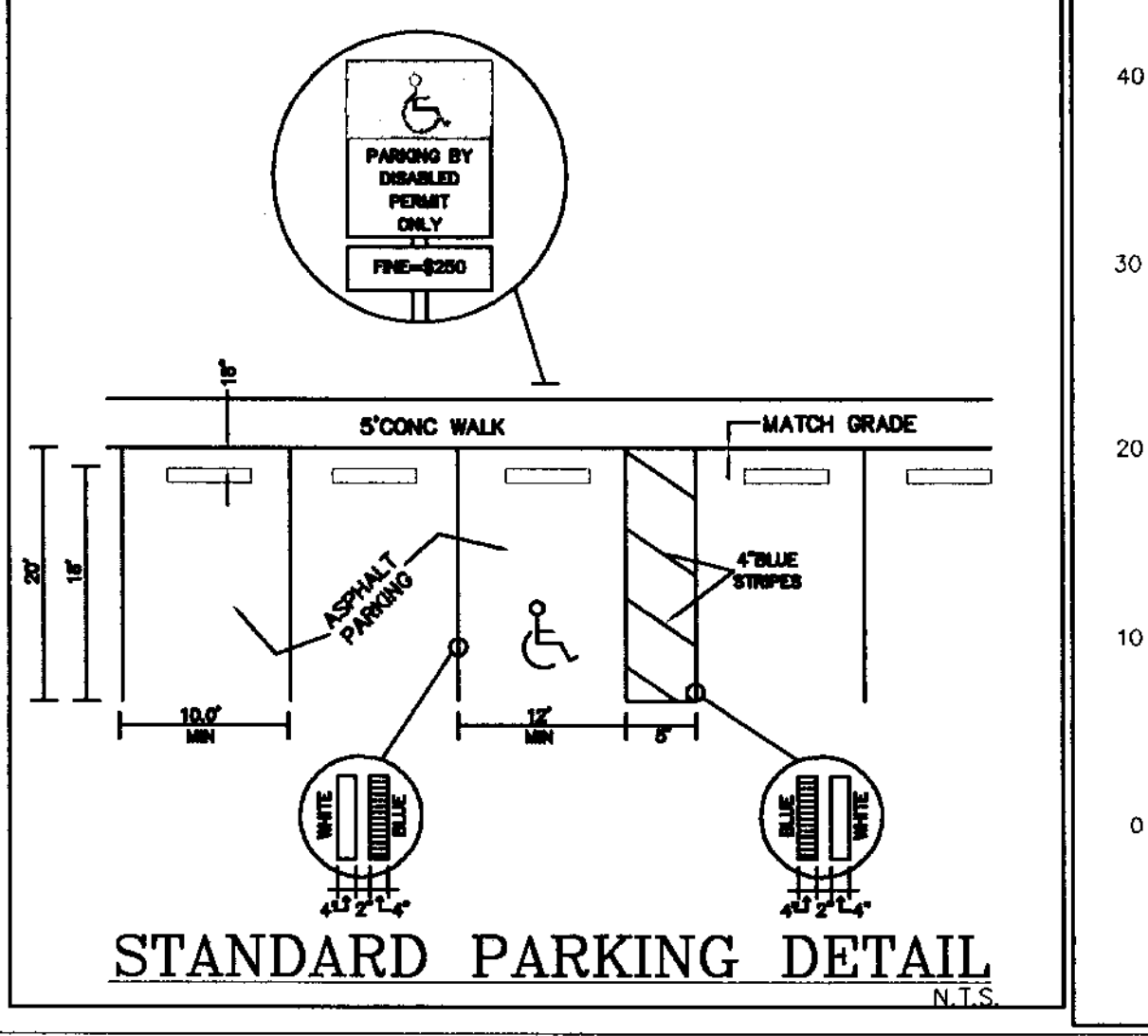

Date	Revisions	Appr. by	Date	Revised	Scale	N.T.S.	Desg.	F309F	Fig.	309F
------	-----------	----------	------	---------	-------	--------	-------	-------	------	------

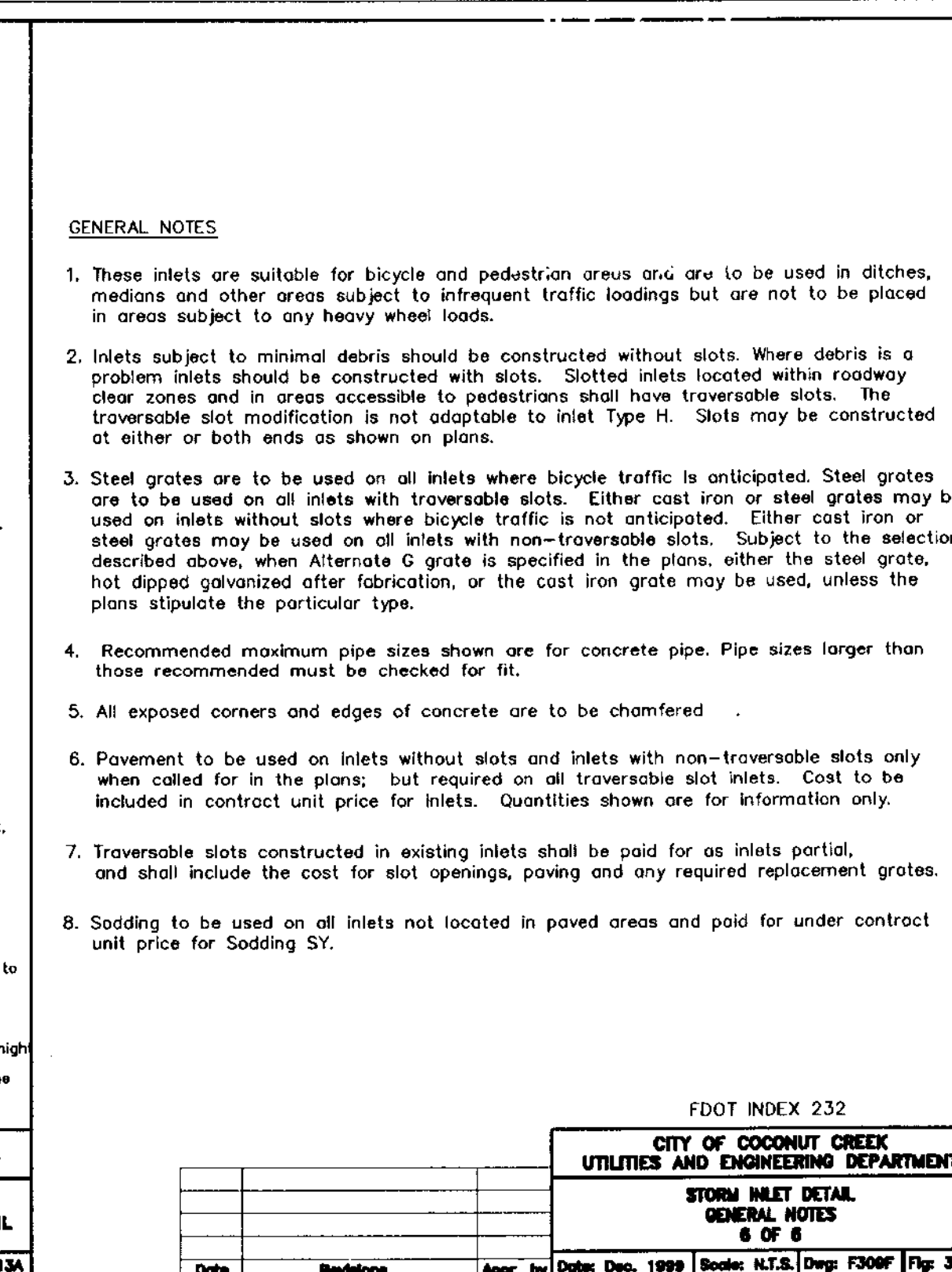

Date	Revisions	Appr. by	Date	Revised	Scale	N.T.S.	Desg.	F304	Fig.	304
------	-----------	----------	------	---------	-------	--------	-------	------	------	-----

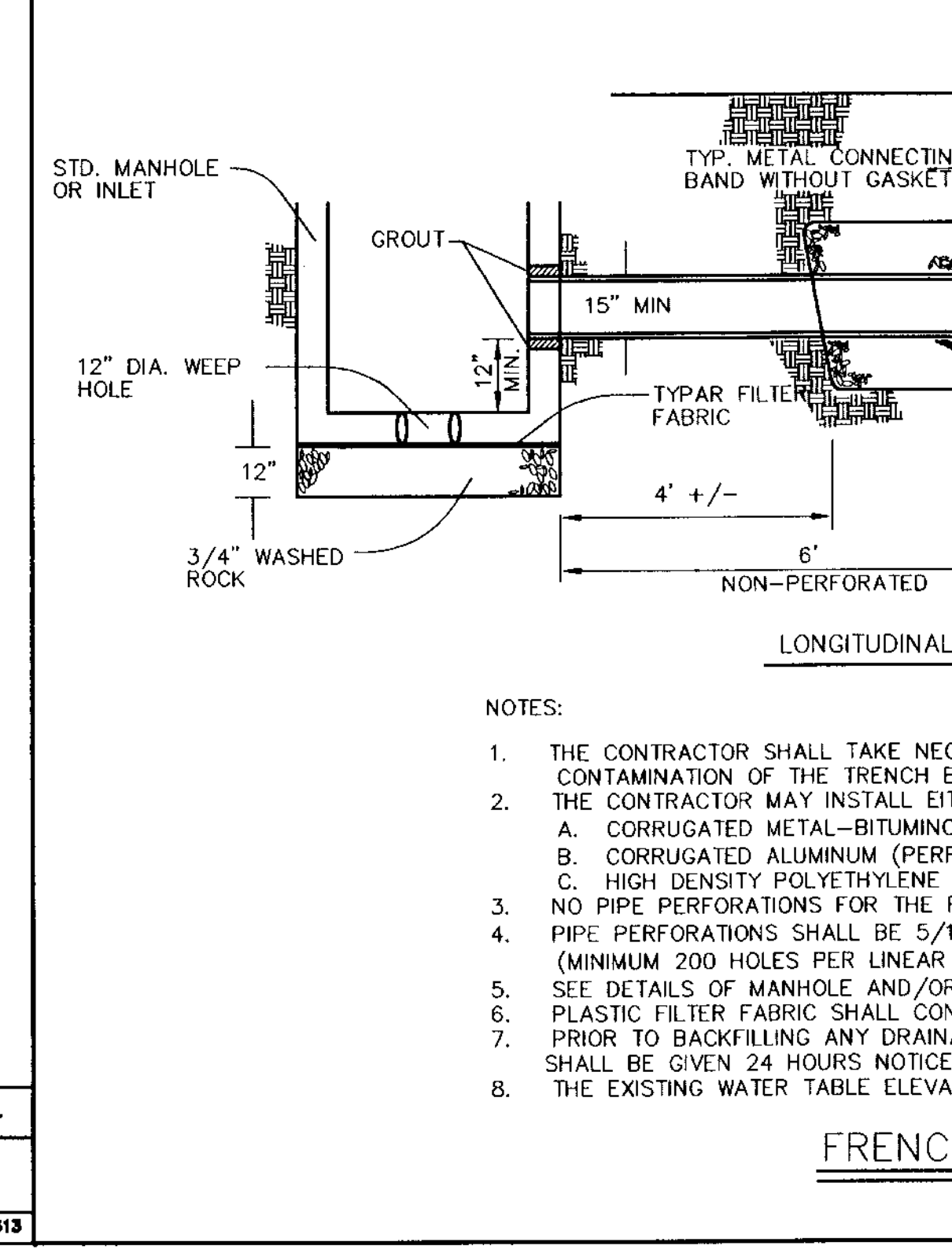

Date	Revisions	Appr. by	Date	Revised	Scale	N.T.S.	Desg.	F309F	Fig.	309F
------	-----------	----------	------	---------	-------	--------	-------	-------	------	------

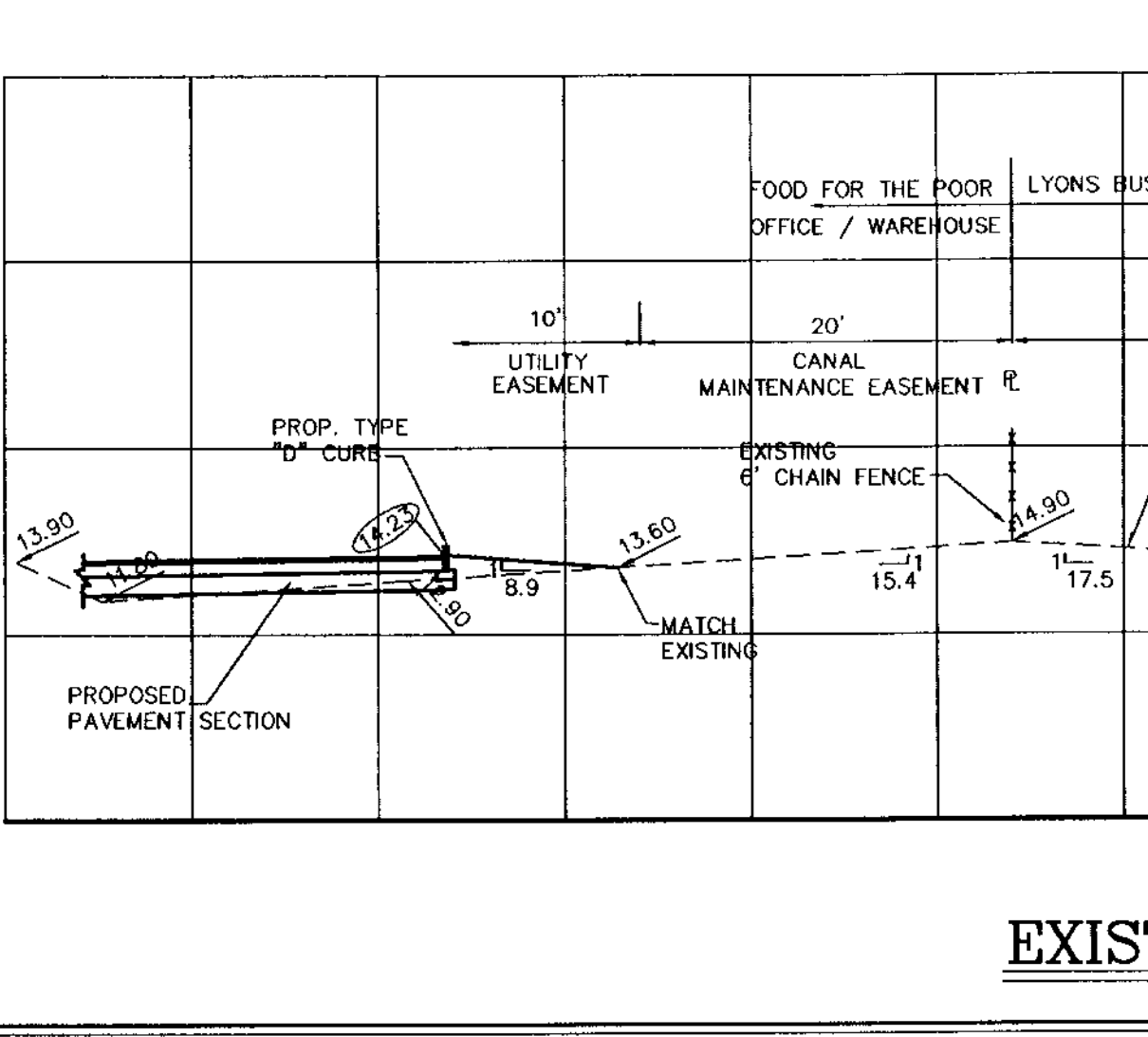

Date	Revisions	Appr. by	Date	Revised	Scale	N.T.S.	Desg.	F313	Fig.	313
------	-----------	----------	------	---------	-------	--------	-------	------	------	-----

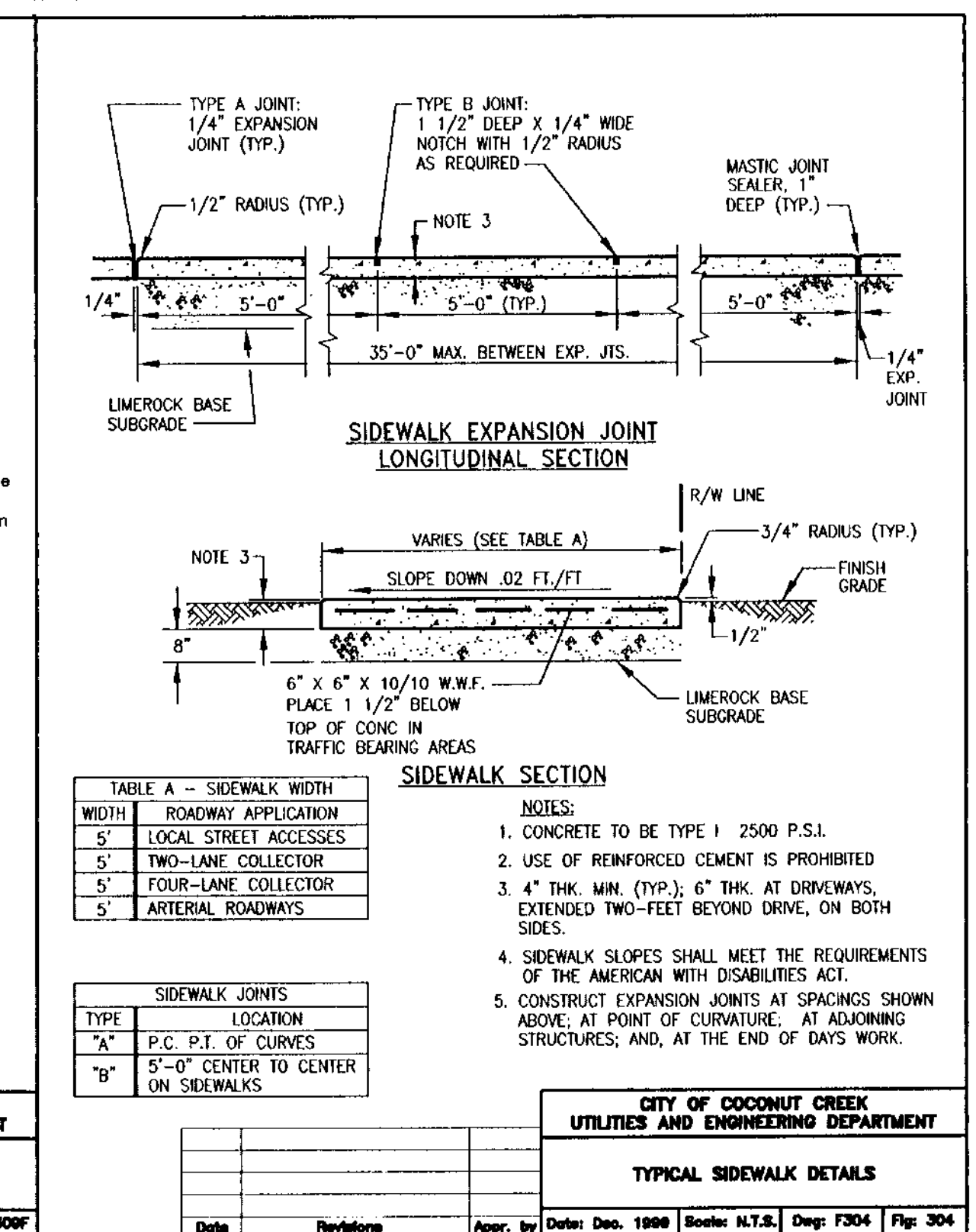

Date	Revisions	Appr. by	Date	Revised	Scale	N.T.S.	Desg.	F304	Fig.	304
------	-----------	----------	------	---------	-------	--------	-------	------	------	-----

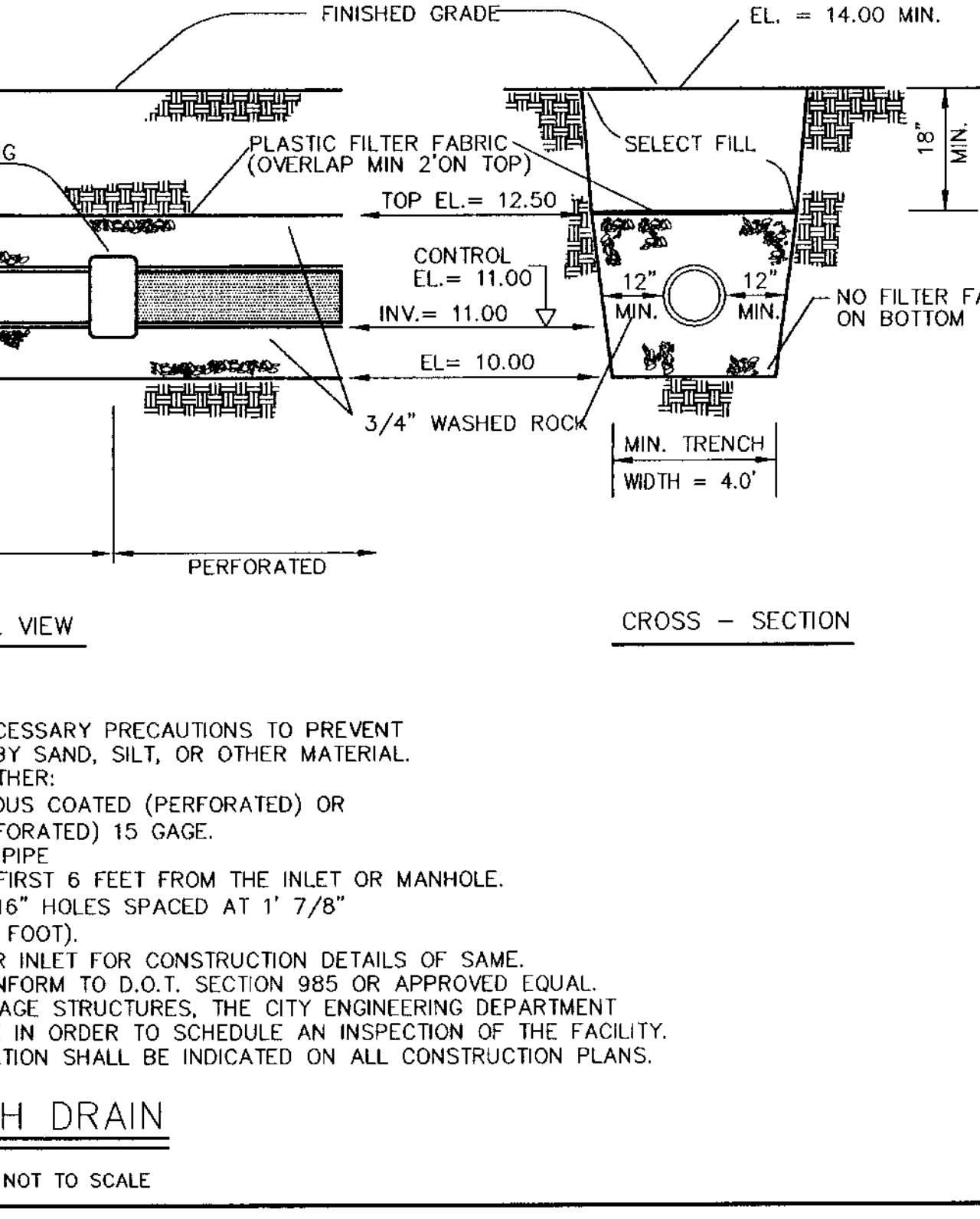

Date	Revisions	Appr. by	Date	Revised	Scale	N.T.S.	Desg.	F309F	Fig.	309F
------	-----------	----------	------	---------	-------	--------	-------	-------	------	------

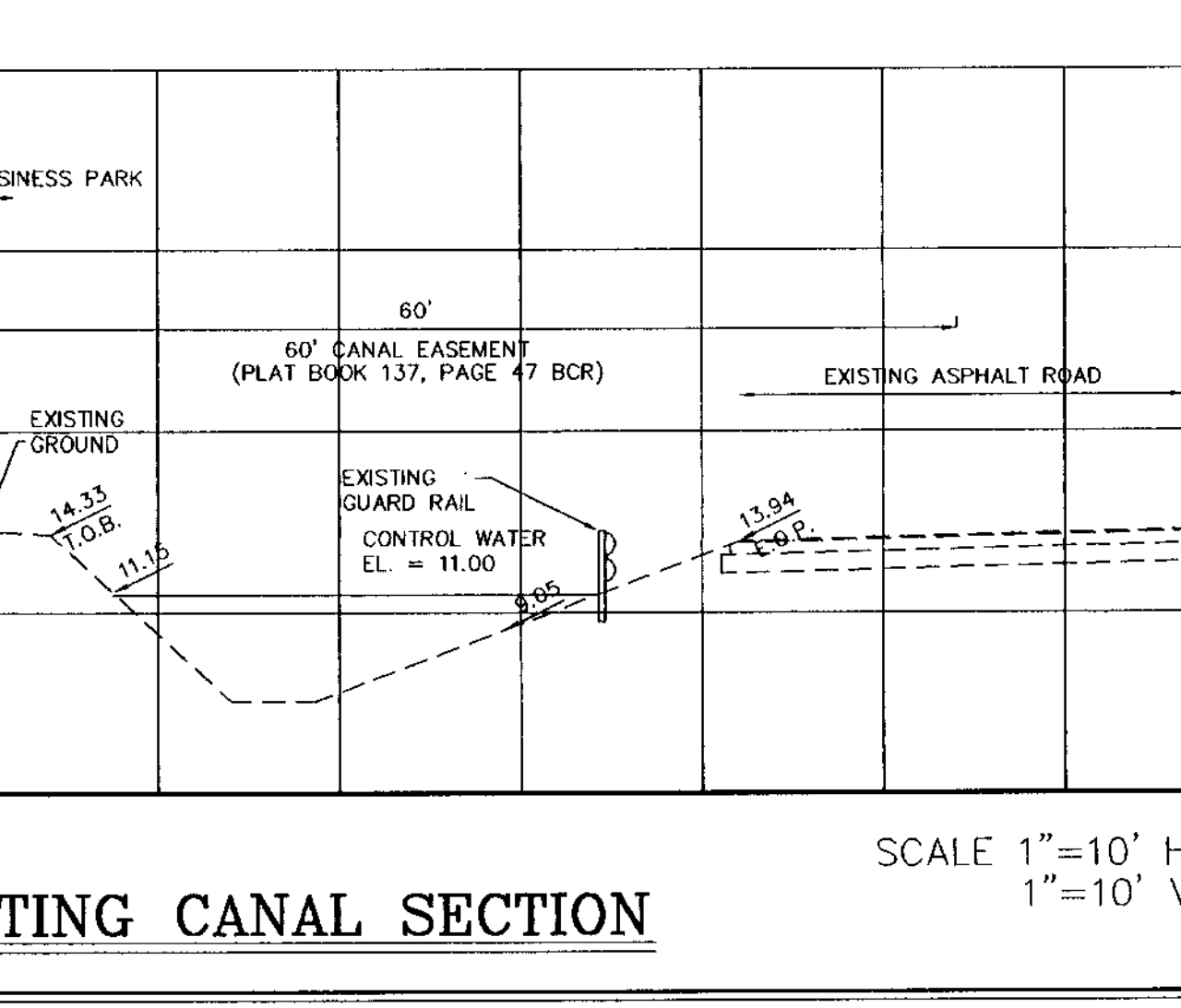

Date	Revisions	Appr. by	Date	Revised	Scale	N.T.S.	Desg.	F309F	Fig.	309F
------	-----------	----------	------	---------	-------	--------	-------	-------	------	------

REVISIONS	DATE	BY

CAULFIELD & WHEELER, INC.
 CIVIL ENGINEERING - LAND PLANNING
 LANDSCAPE ARCHITECTURE - SURVEYING
 7301A W. PALMETTO PARK ROAD - SUITE 100A
 BOCA RATON, FLORIDA 33433
 PHONE (561) 392-1991 / FAX (561) 750-1452

FOOD FOR THE POOR
 OFFICE / WAREHOUSE
 PAVING, GRADING &
 DRAINAGE DETAILS
 COCONUT CREEK, FLORIDA

DATE	2/19/04
DRAWN BY	BAH
F.B./P.C.	N/A
SCALE	N.T.S.
DATE	05/20/04
BY	PHN F. WHEELER
CERT. NO.	25478
STATE OF FLORIDA	ENG. NO. EB-0003591
JOB #	3212
SHT. NO.	C-5
OF 14 SHEETS	