

BCED REF#:

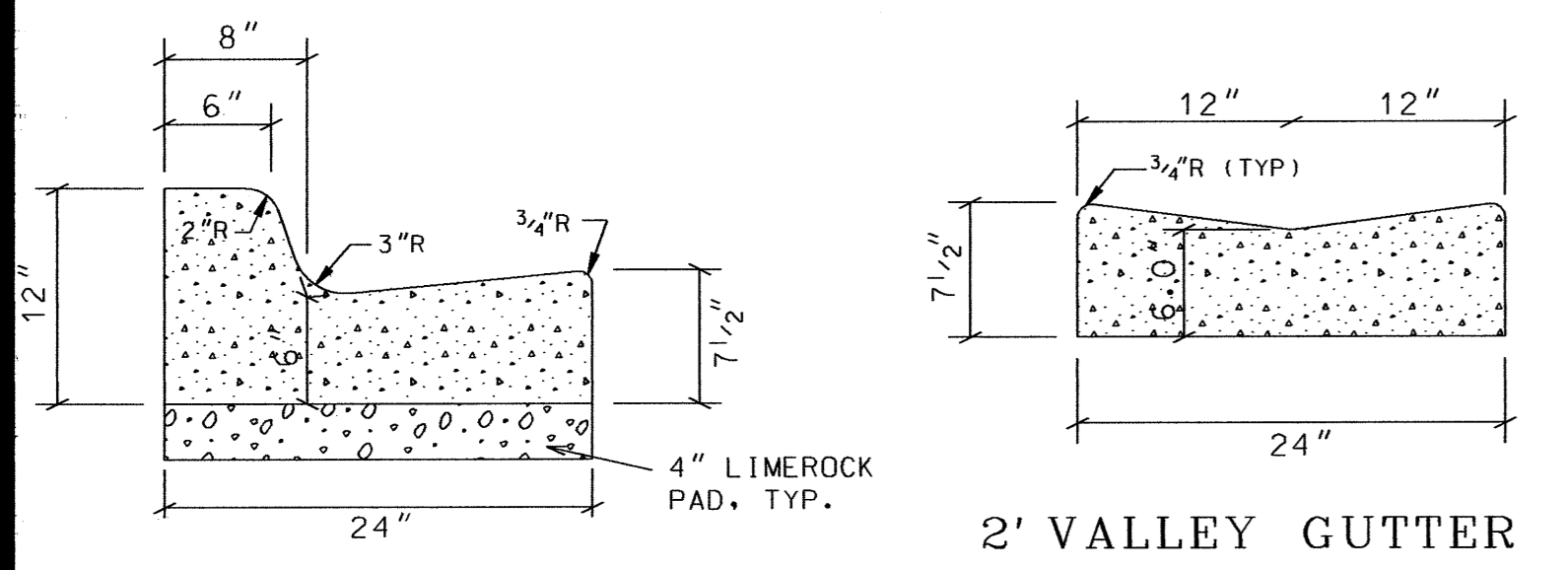

**TYPE "F" CONCRETE CURB & GUTTER**  
NOT TO SCALE

**2' VALLEY GUTTER SYMMETRICAL**  
NOT TO SCALE

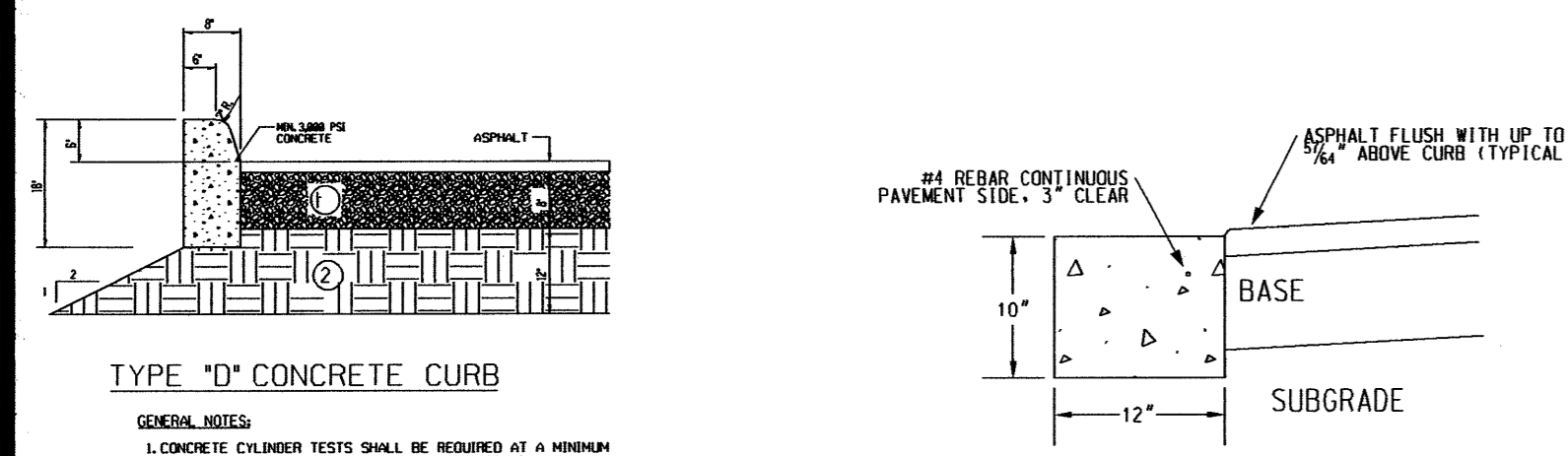

**TYPE "D" CONCRETE CURB**

**HEADER CURB**  
N.T.S.

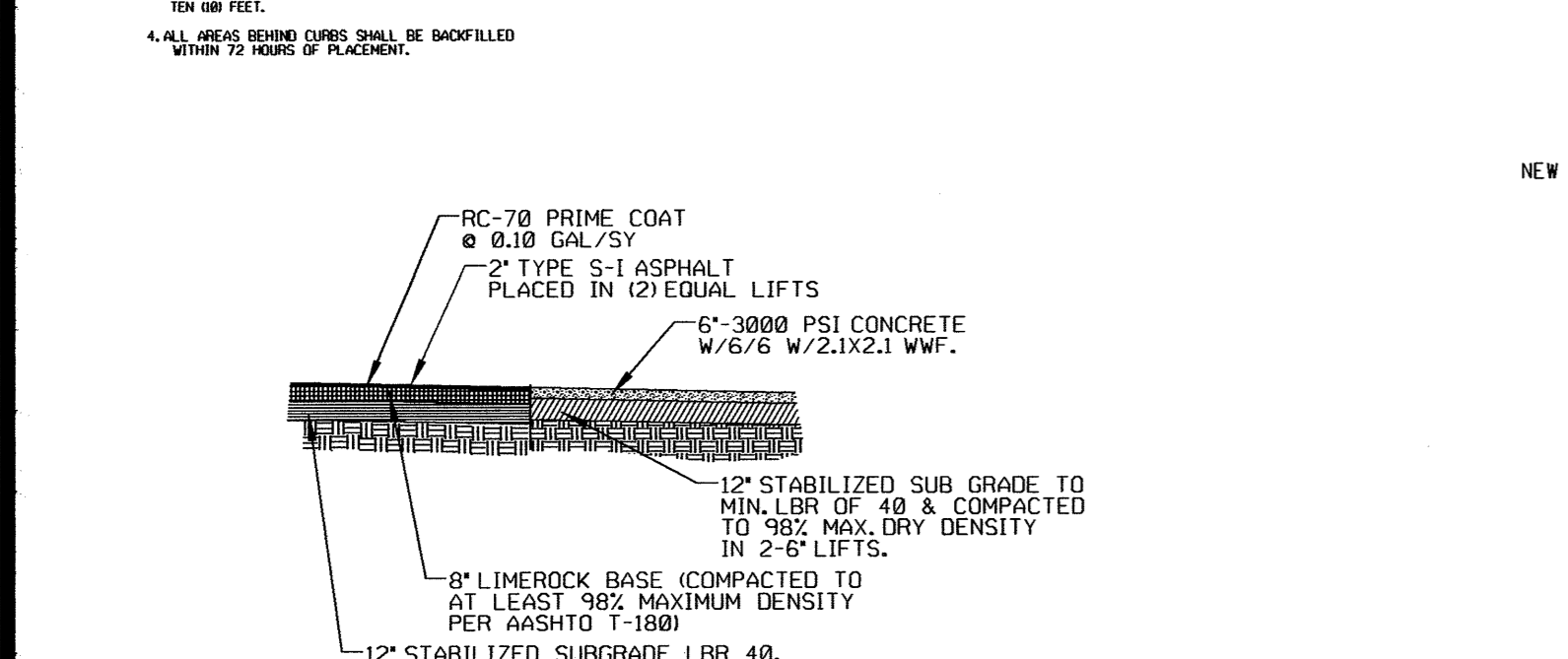

**ASPHALT-CONCRETE CONNECTION DETAIL**

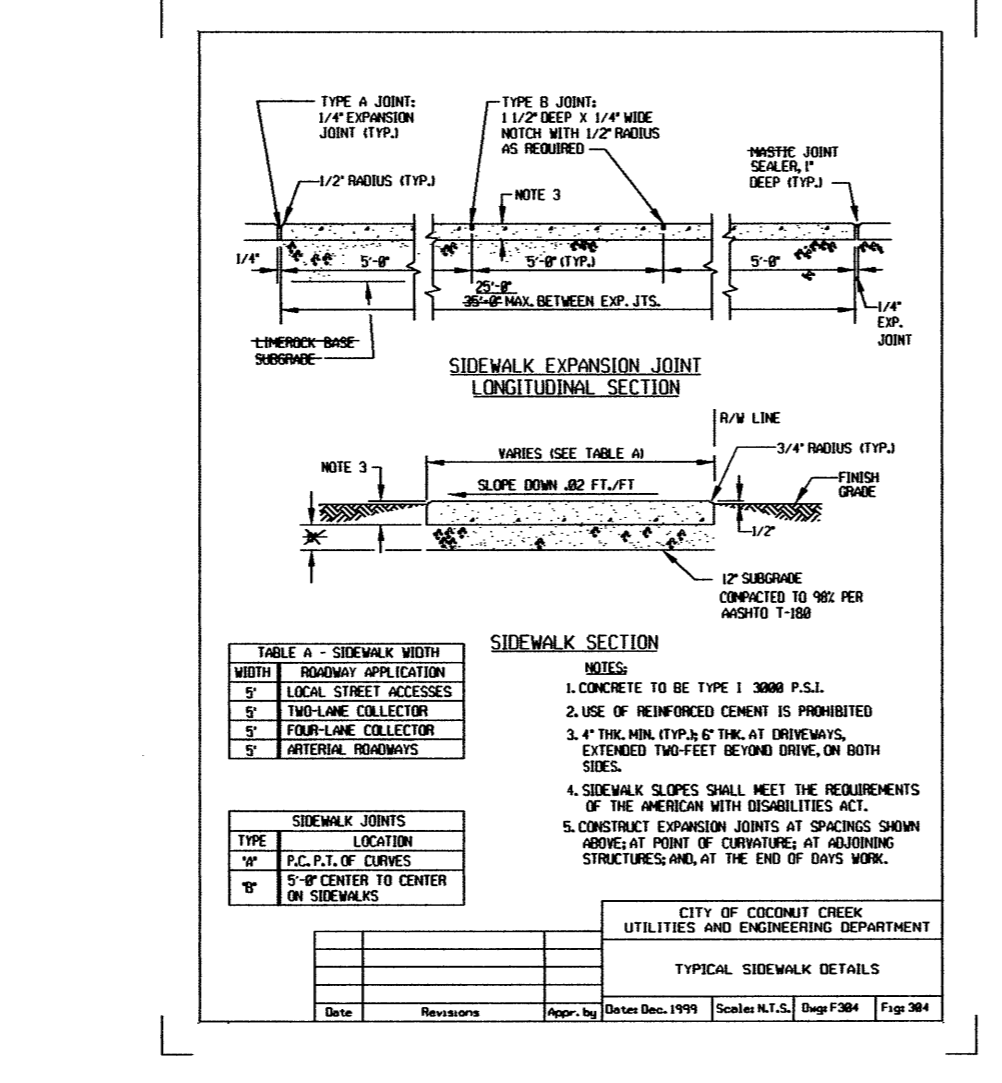
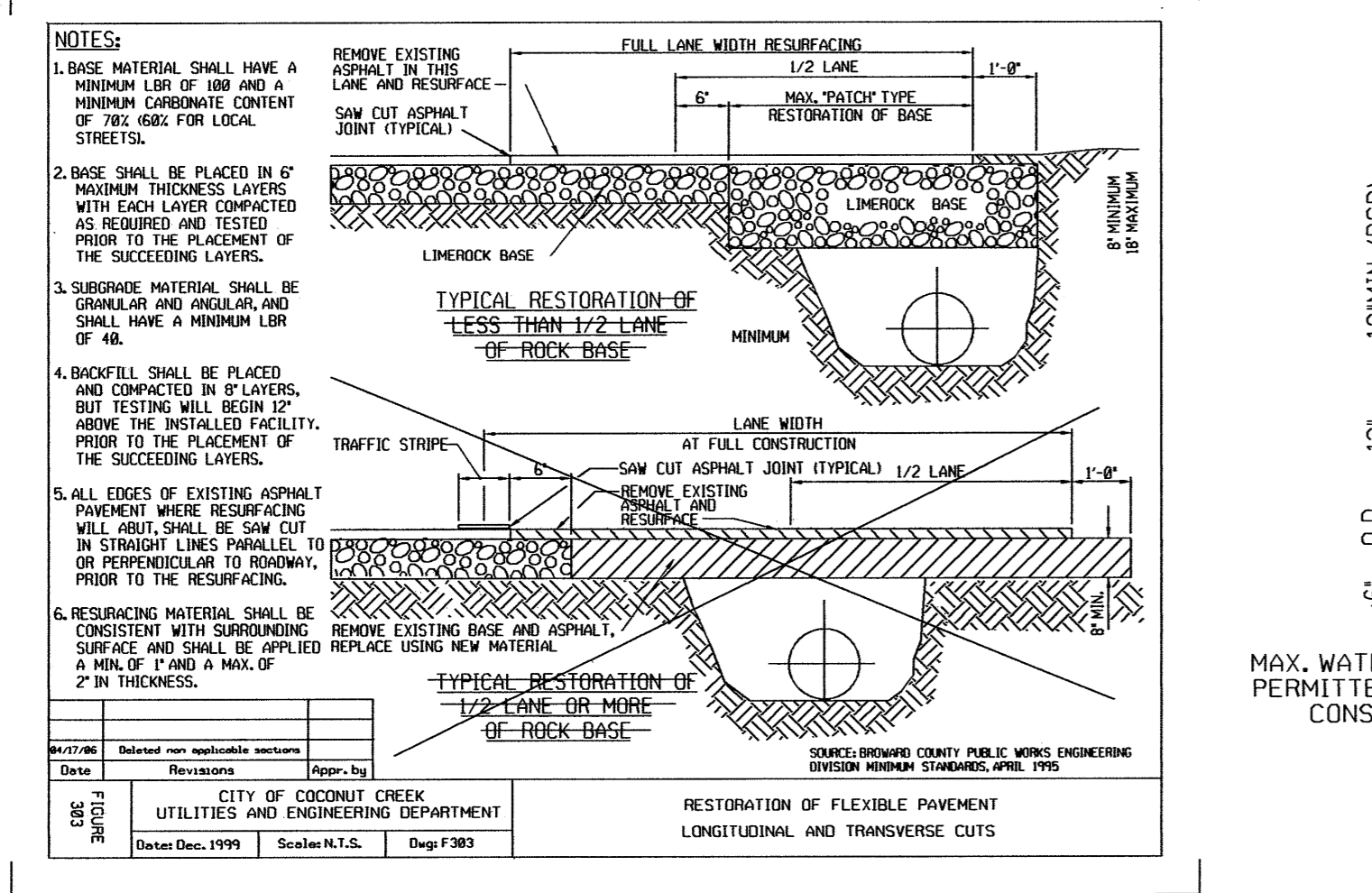
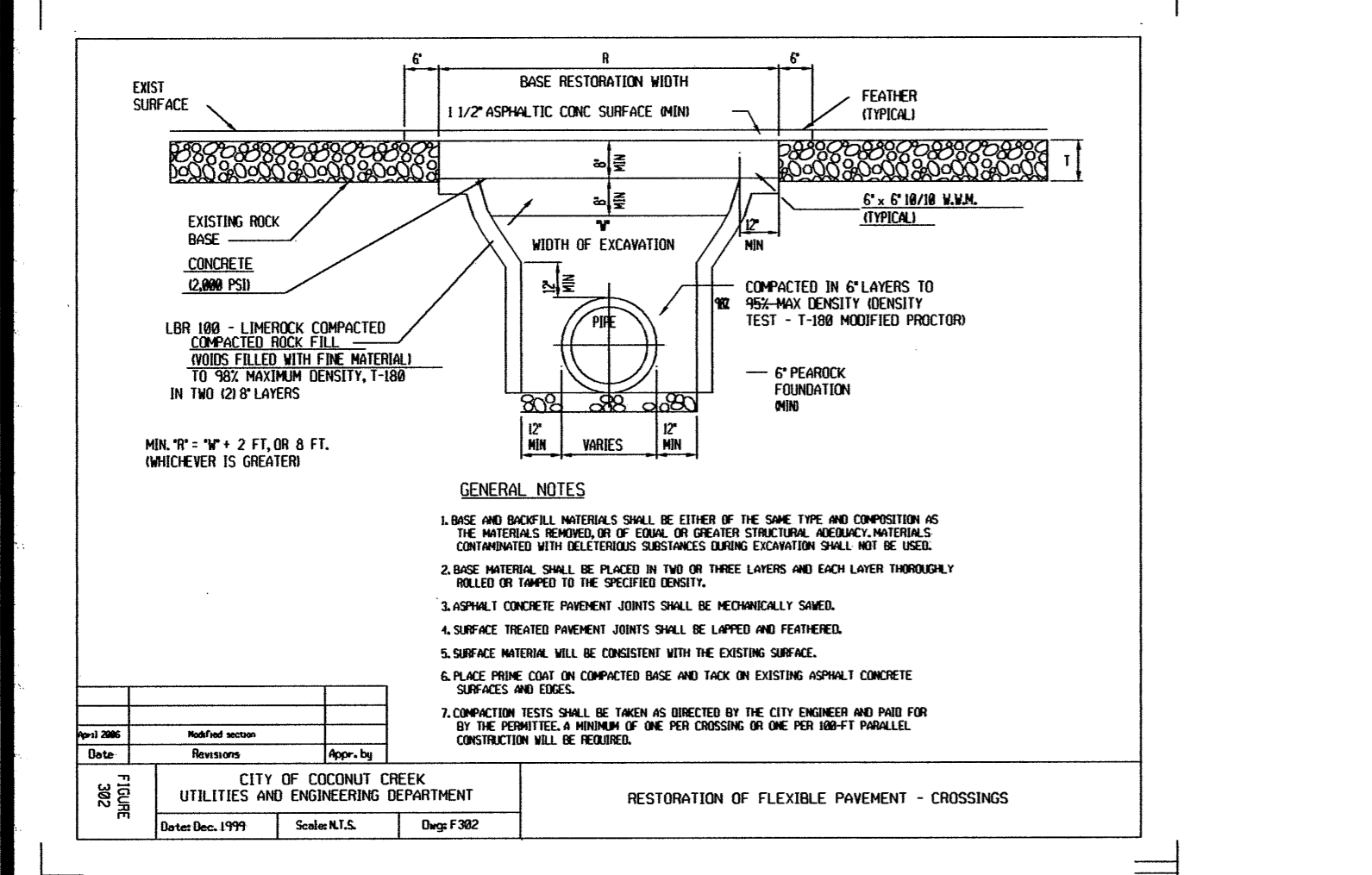

**TYPICAL SIDEWALK DETAILS**

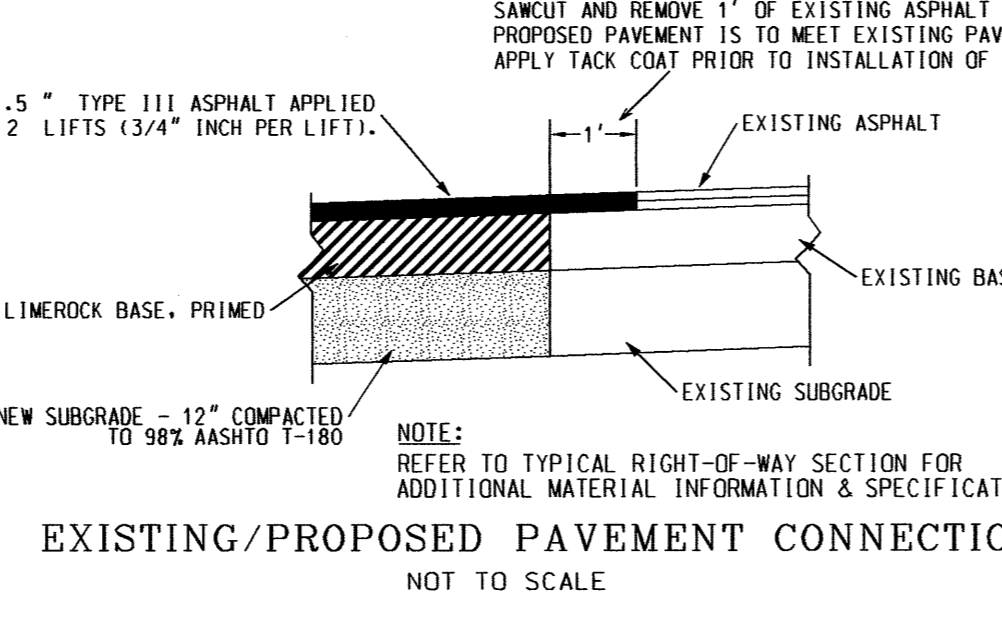

**EXISTING/PROPOSED PAVEMENT CONNECTION**  
NOT TO SCALE

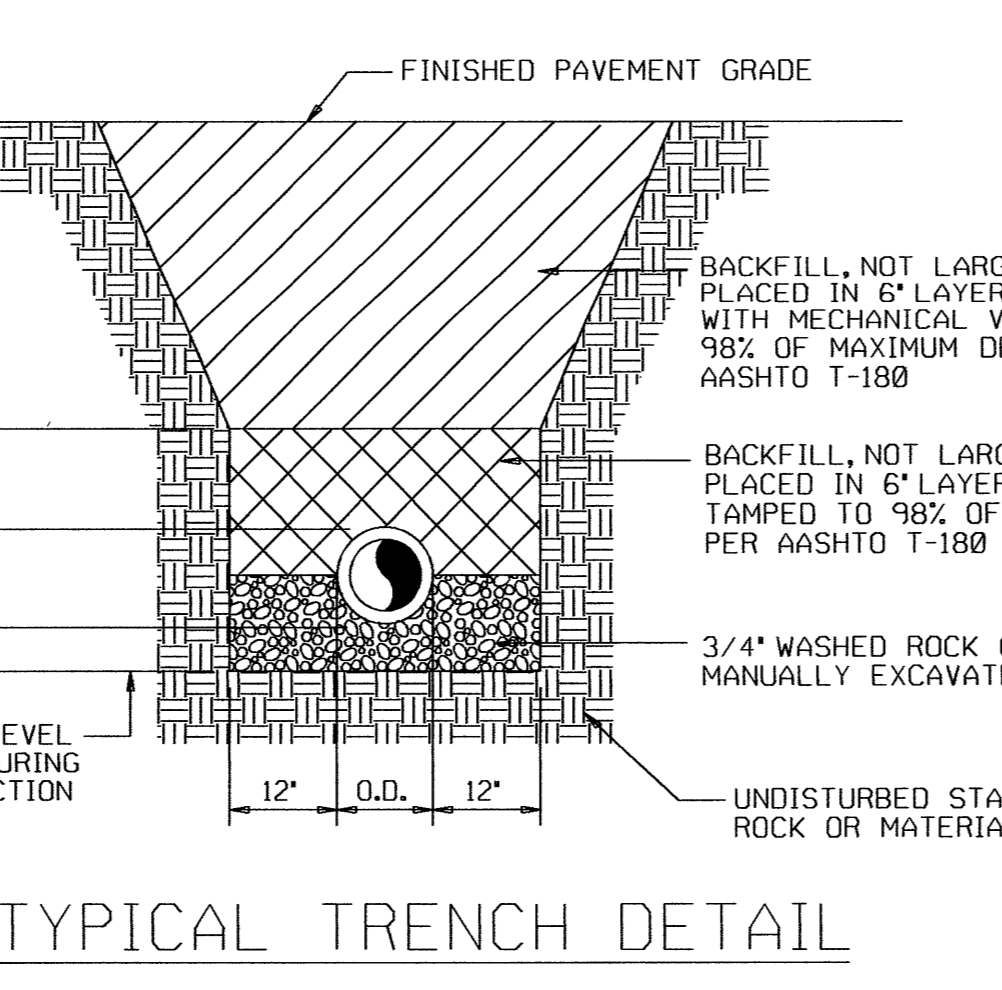
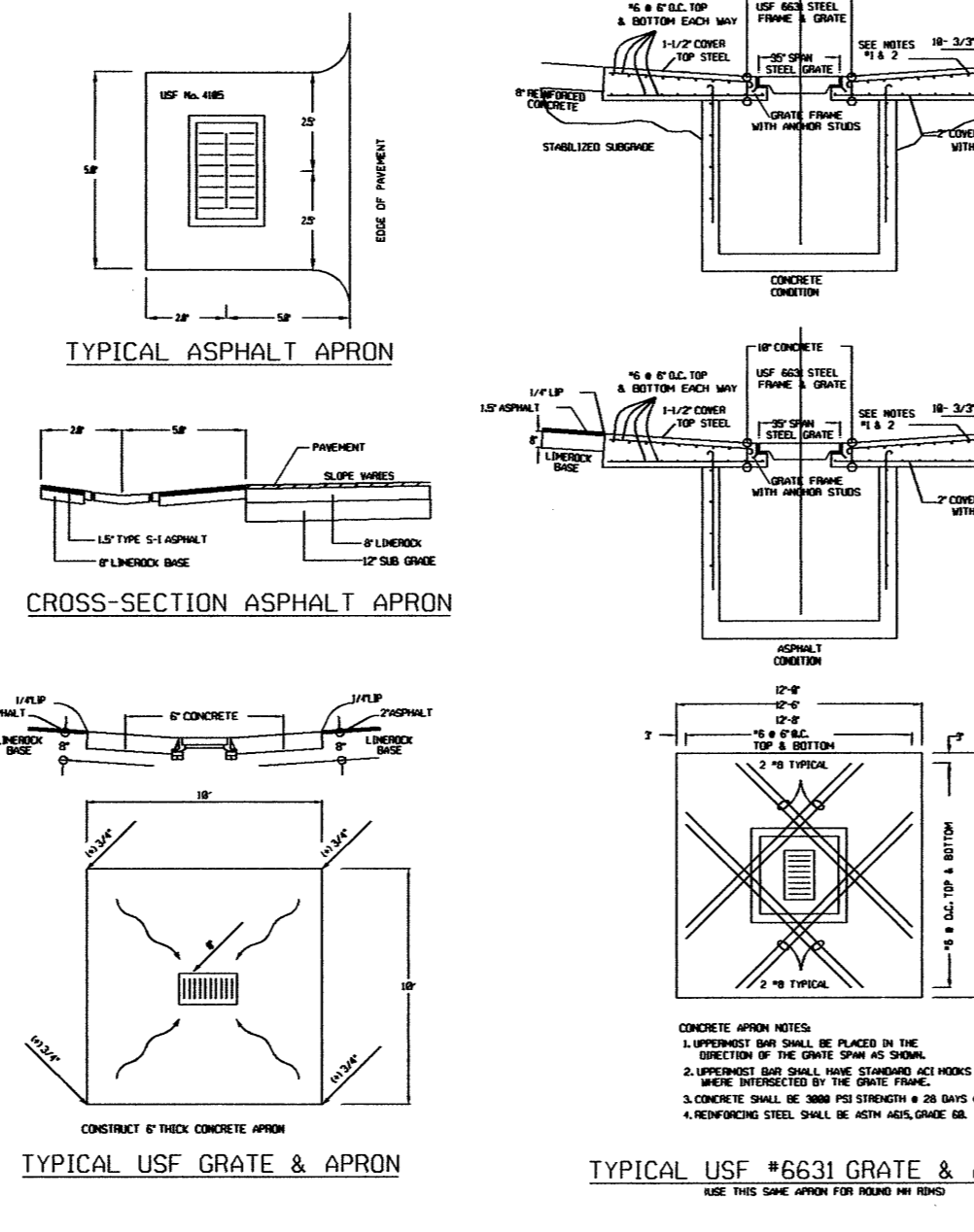

**TYPICAL TRENCH DETAIL**

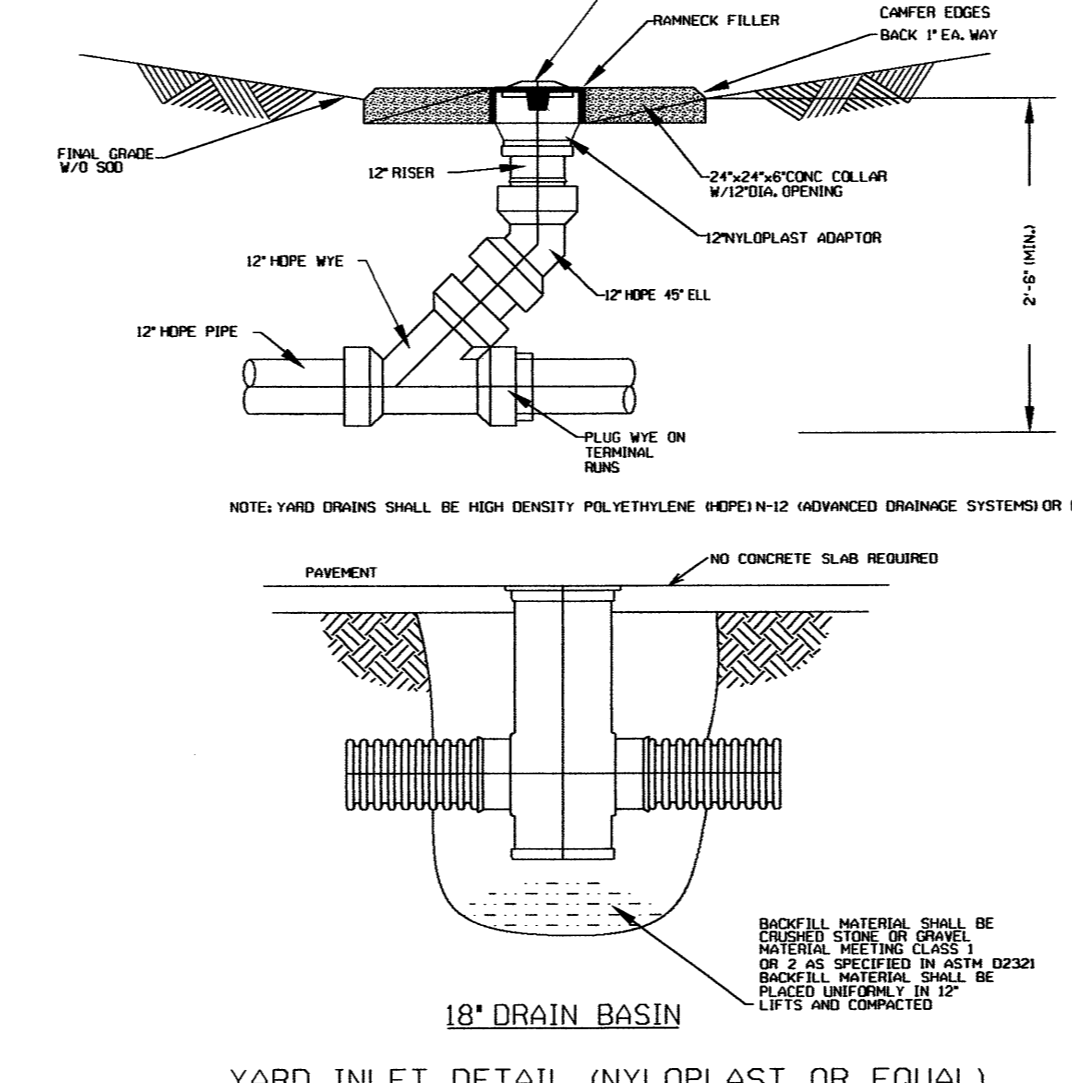

**18" DRAIN BASIN**

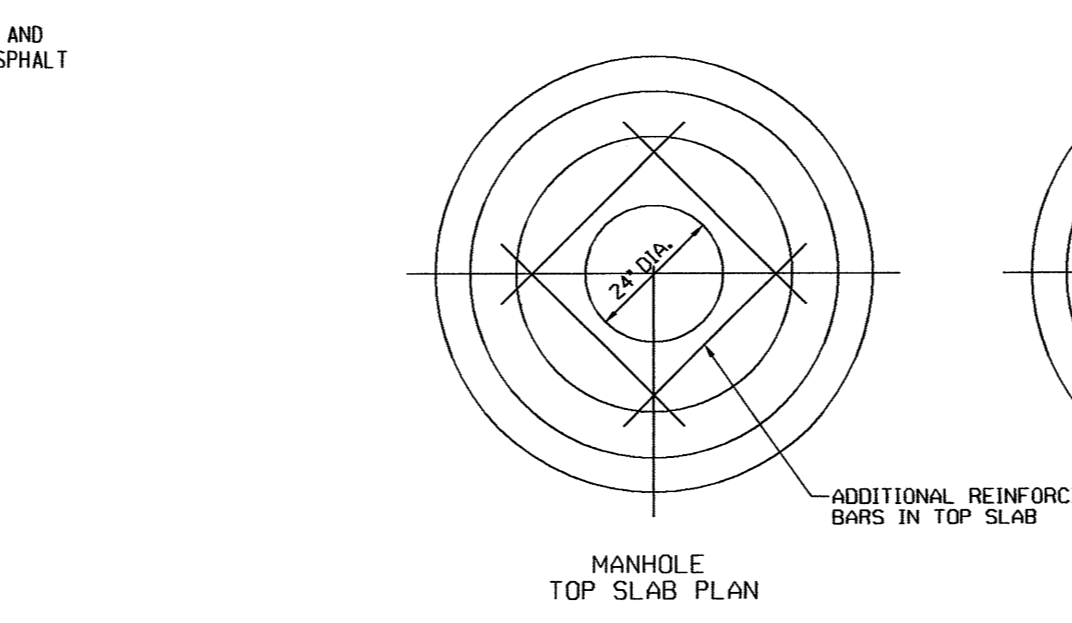

**MANHOLE TOP SLAB PLAN**  
**CATCH BASIN TOP SLAB PLAN**

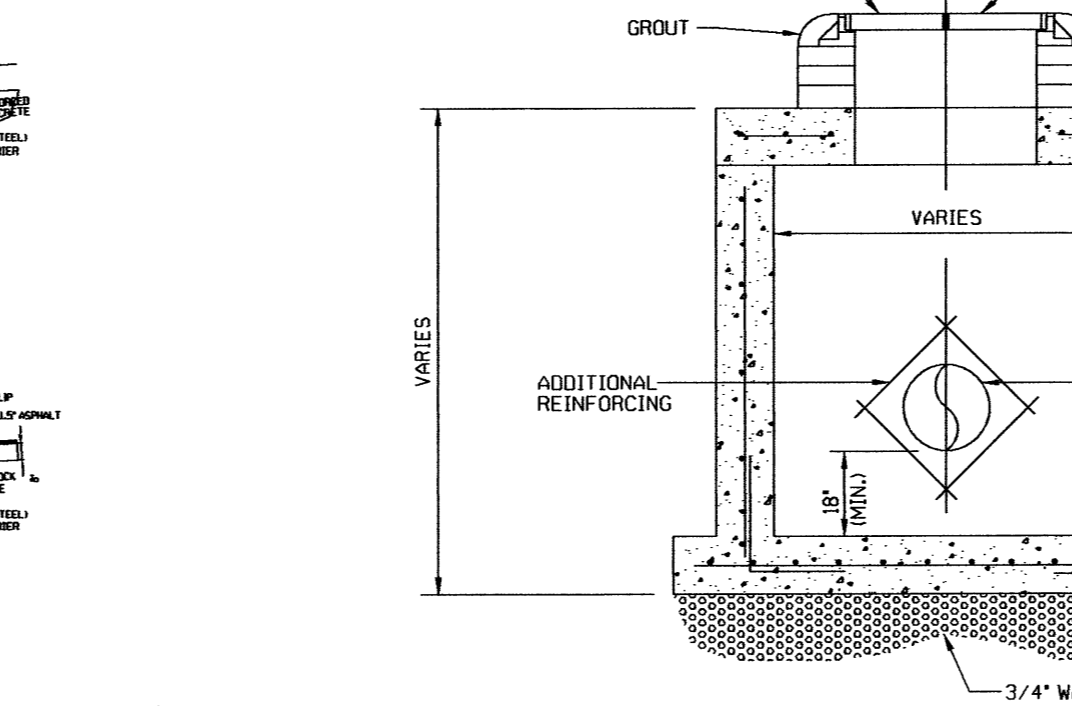

**STANDARD MANHOLE DETAIL**  
NOT TO SCALE

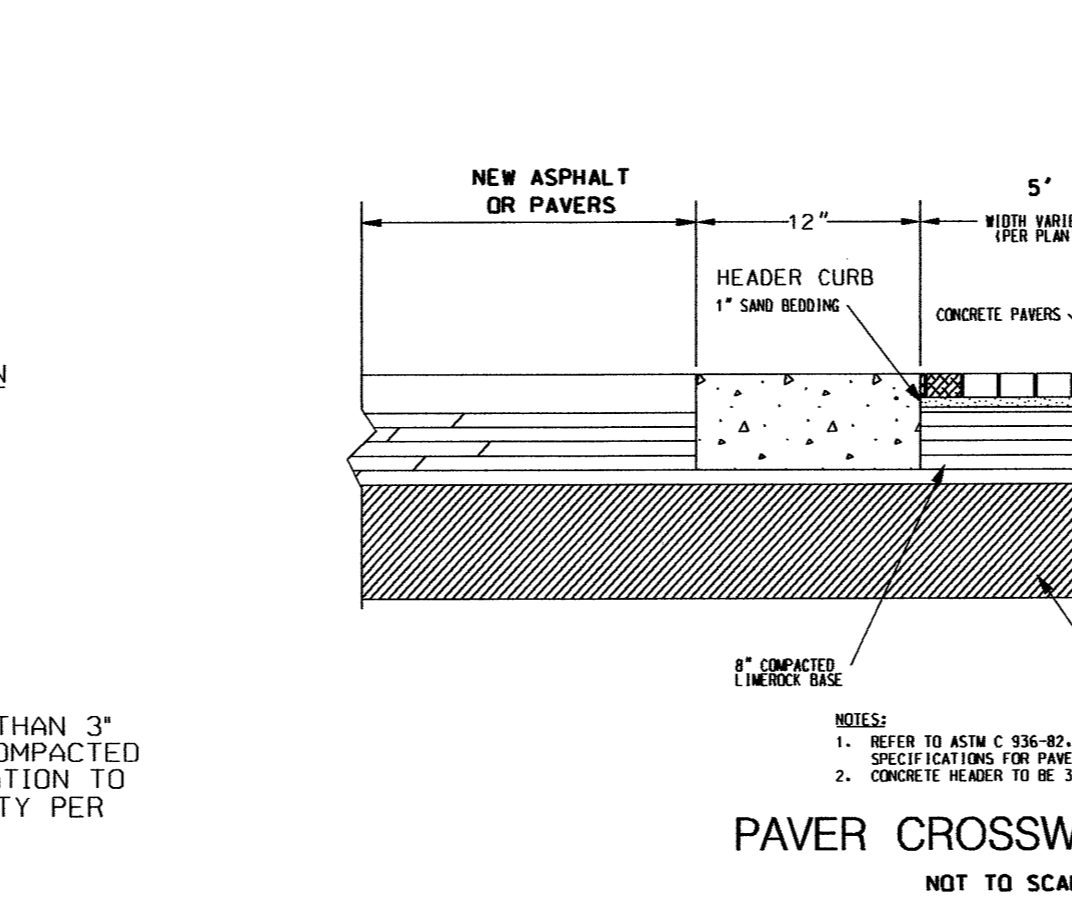

**PAVER CROSSWALK DETAIL**  
NOT TO SCALE

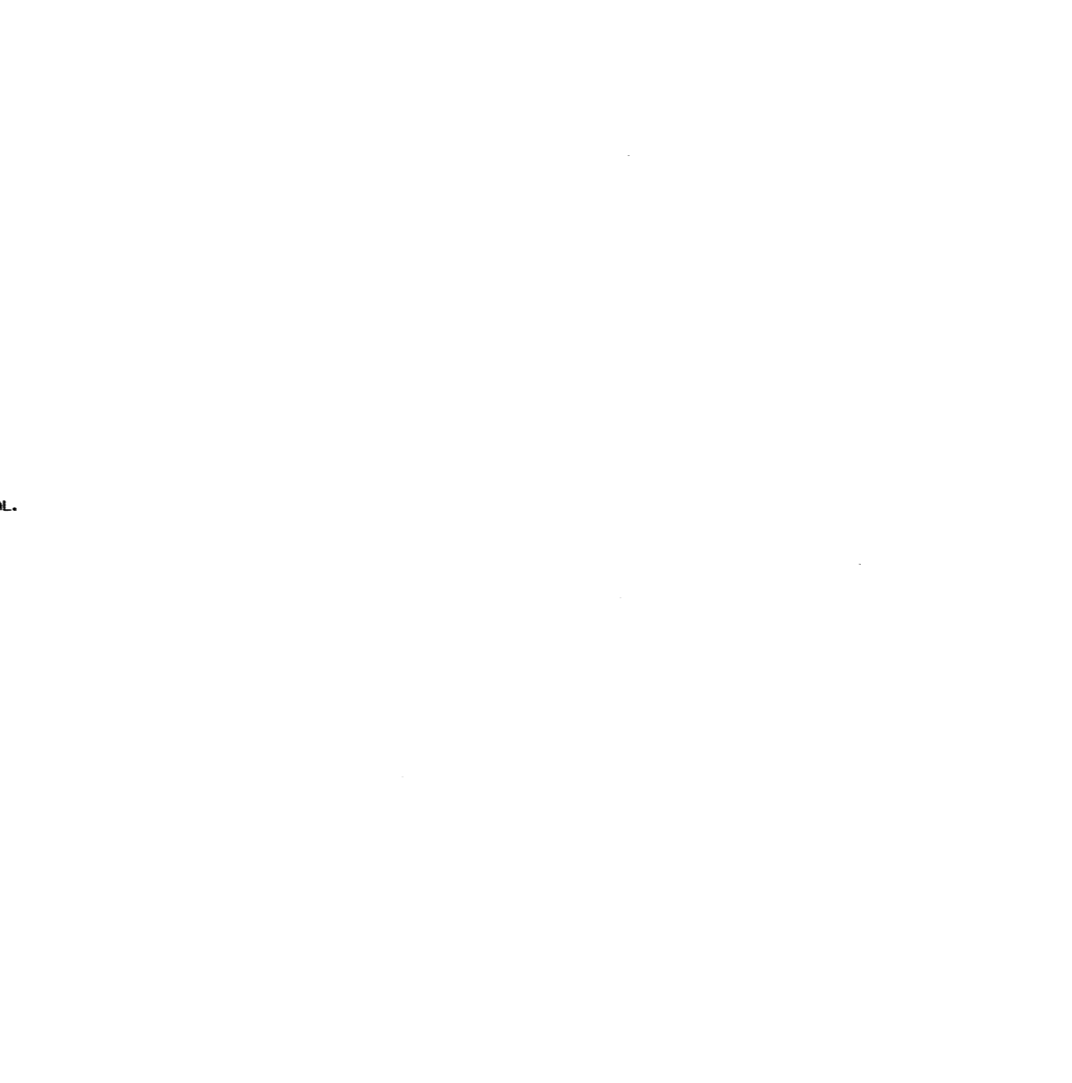

**TYPE "C" CATCH BASIN DITCH BOTTOM INLET**  
NOT TO SCALE

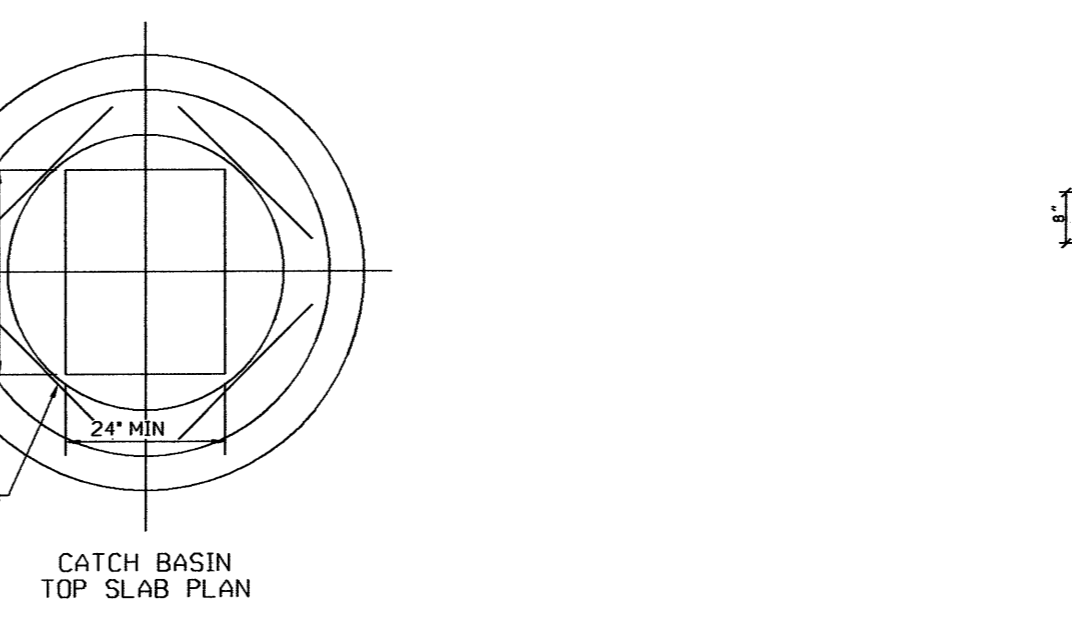

**TYPE "C" CATCH BASIN IN VALLEY GUTTER**  
NOT TO SCALE

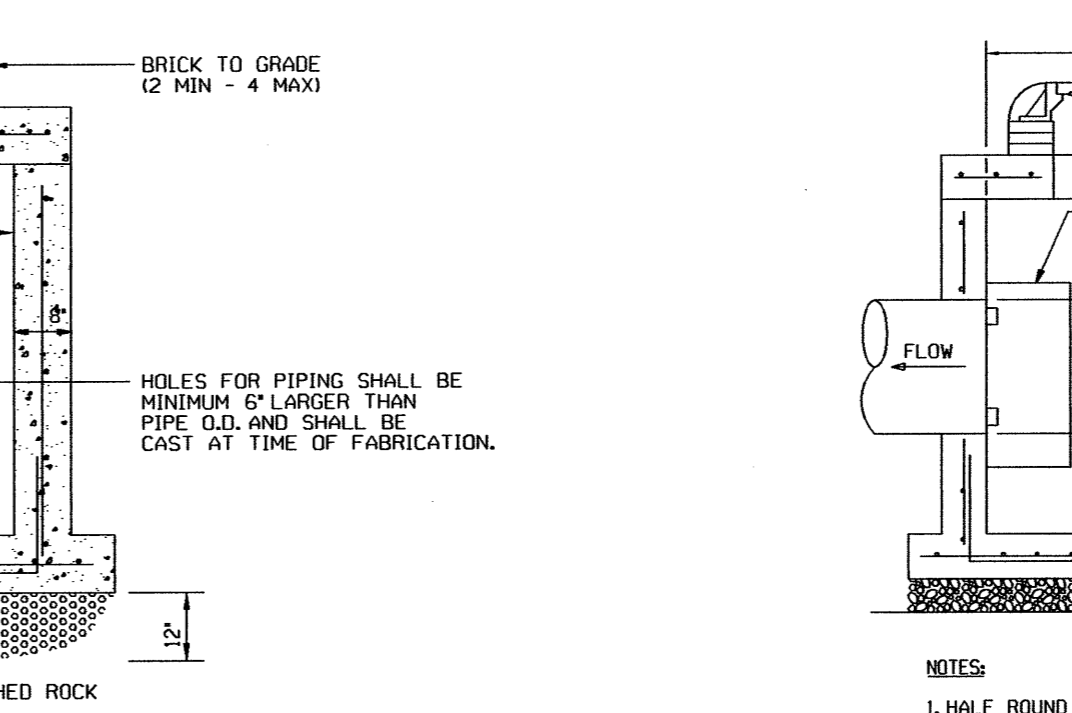

**STANDARD MANHOLE DETAIL**  
NOT TO SCALE

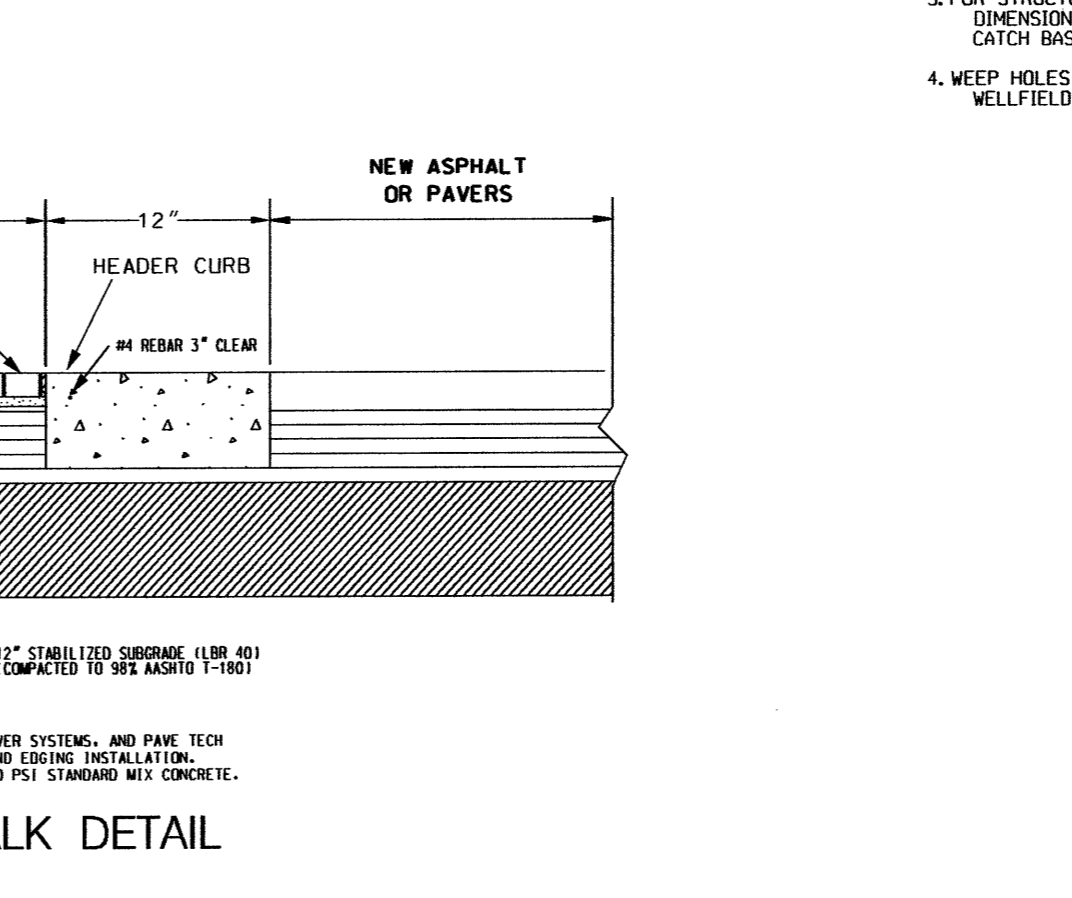

**PAVER CROSSWALK DETAIL**  
NOT TO SCALE

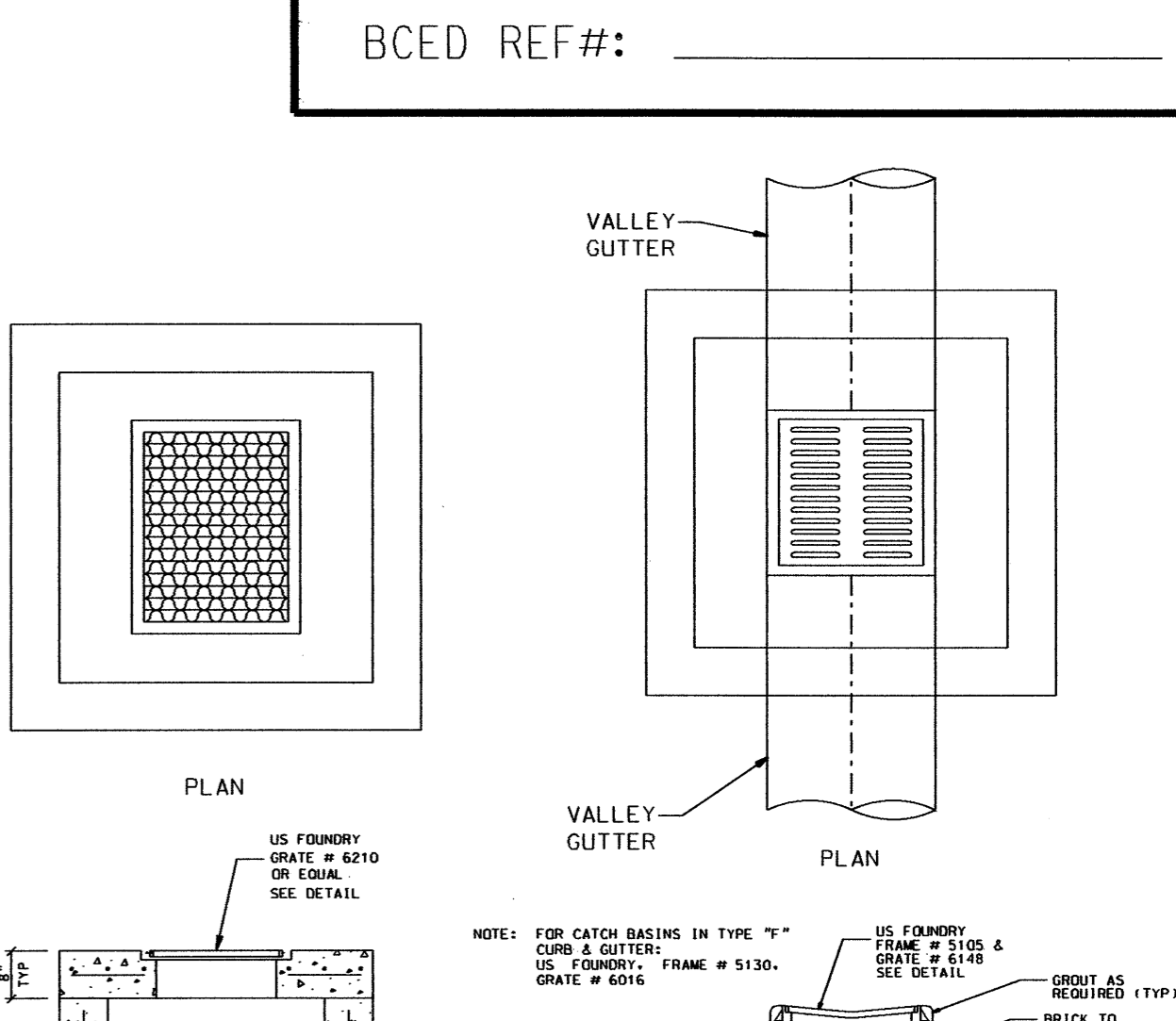

**TYPE "C" CATCH BASIN**  
NOT TO SCALE

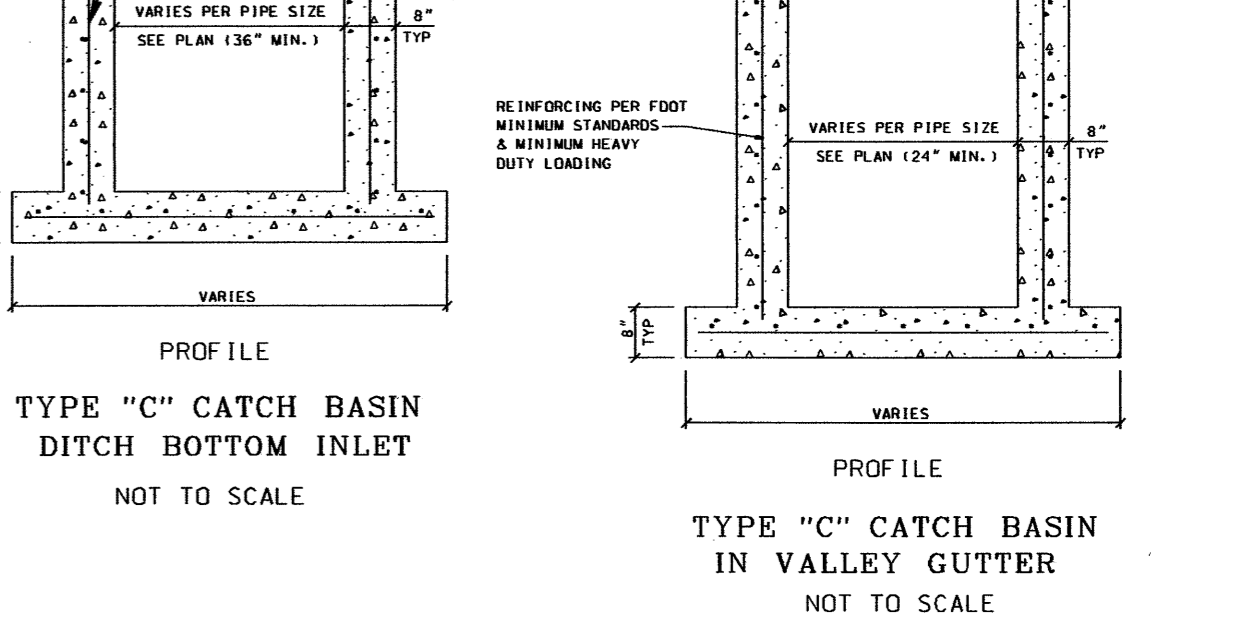

**TYPE "C" CATCH BASIN IN VALLEY GUTTER**  
NOT TO SCALE

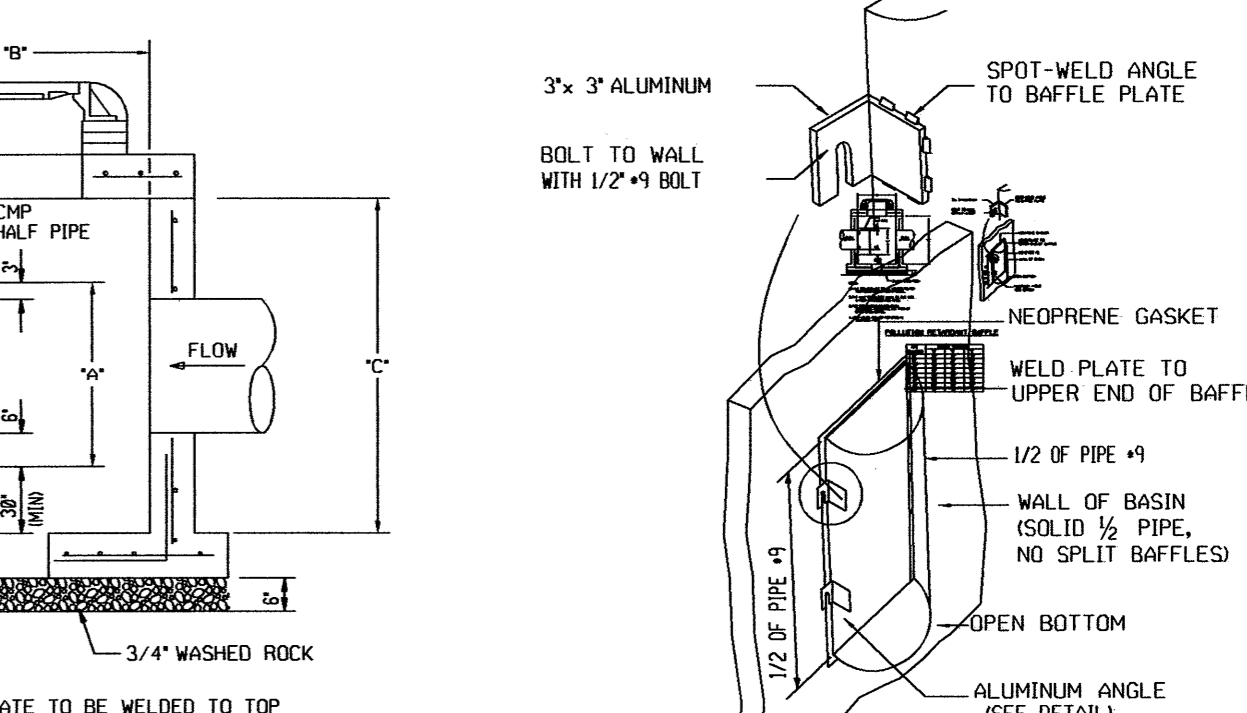

**POLLUTION RETARDANT BAFFLE**

PIPE DIAMETER	BAFFLE SCHEDULE		
	18"	24"	30"
15"	27"	24"	37"
18"	30"	24"	37"
24"	36"	36"	36"
30"	42"	36"	42"
36"	48"	42"	54"
42"	54"	48"	60"
48"	60"	54"	66"
60"	72"	72"	72"

CITY OF COCONUT CREEK PERMIT SET MUST BE ON SITE AT ALL TIMES DURING CONSTRUCTION. NOTICE INSPECTION REQUIRED 48 HRS. PRIOR TO COMMENCING ANY WORK IN THE PUBLIC RIGHT OF WAY CONTACT THE CITY OF COCONUT CREEK ENGINEERING DEPARTMENT FOR INSPECTION.

NOTE: APPROVAL OF THIS PLAN DOES NOT CONSTITUTE A PERMIT FOR CONSTRUCTION. A PERMIT FOR CONSTRUCTION MUST BE OBTAINED FROM THE CITY OF COCONUT CREEK ENGINEERING DEPARTMENT PRIOR TO COMMENCING CONSTRUCTION IN THE PUBLIC RIGHT OF WAY.

48 HOURS BEFORE DIGGING CALL SUNSHINE TOLL FREE 1-800-432-4770 UNDERGROUND UTILITIES NOTIFICATION CENTER OF FLORIDA

PROJECT: <b>IN THE PINES</b>	TITLE: <b>PAVING, GRADING, &amp; DRAINAGE DETAILS</b>	SHEET NUMBER: <b>PD5</b>
DATE: 05/15/14	REVISIONS:	OF 6
SCALE: NA	DATE: 2/2	COMMENTS:
DRAWN BY: BEJ	CHECKED BY: IJL	APPROVED BY: BEJ
PROJECT #: 13-0020	DATE:	

HOWARD JABLON, P. E. #47514 DATE