

T-Mobile

stick together

LAKE SIDE PARK

5555 REGENCY BOULEVARD
COCONUT CREEK, FL 33073

6FB1173B

L700 Mhz PROJECT

DO NOT SCALE DRAWINGS. CONTRACTOR MUST VERIFY ALL DIMENSIONS AND ADVISE CONSULTANTS OF ANY ERRORS OR OMISSIONS. NO VARIATIONS OR MODIFICATIONS TO WORK SHOWN SHALL BE IMPLEMENTED WITHOUT PRIOR WRITTEN APPROVAL. ALL PREVIOUS ISSUES OF THIS DRAWING ARE SUPERSEDED BY THE LATEST REVISION. ALL DRAWINGS AND SPECIFICATIONS REMAIN THE PROPERTY OF MORRISON HERSHFIELD CORPORATION. NEITHER MORRISON HERSHFIELD NOR THE ARCHITECT WILL BE PROVIDING CONSTRUCTION REVIEW OF THIS PROJECT.

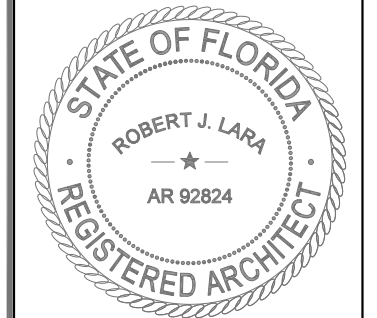

ROBERT JERRY LARA
REGISTERED ARCHITECT
STATE OF FLORIDA
AR92824

5		
4		
3		
2		
1	10/20/14	RE-ISSUED FOR PERMIT
0	09/11/14	ISSUE FOR PERMIT
B	08/12/14	PER CLIENT COMMENTS
A	07/11/14	90% CD SUBMITAL
No.	Date	Action

Client:

1300 CONCORD TERRACE
SUITE 200
SUNRISE, FL. 33323

Consultant:

MORRISON HERSHFIELD
Two South University Drive, Suite 245,
Plantation, FL 33324
Tel: 954.577.4655 Fax: 954.577.4656
FL C OF A #8508
FL Architect business # AA26002368
www.morrisonhershfield.com

Project:

LAKE SIDE PARK
6FB1173B
5555 REGENCY BOULEVARD
COCONUT CREEK, FL 33073

Drawing Title:

COVER SHEET

Project No.: 7140041	
Designer: CT	Date: 07/10/14
Drawn By: XL	Checked By: RL
PM Review: LP	Client Approval
Issue No.: 1	Drawing No.: T-1

LOCAL MAP

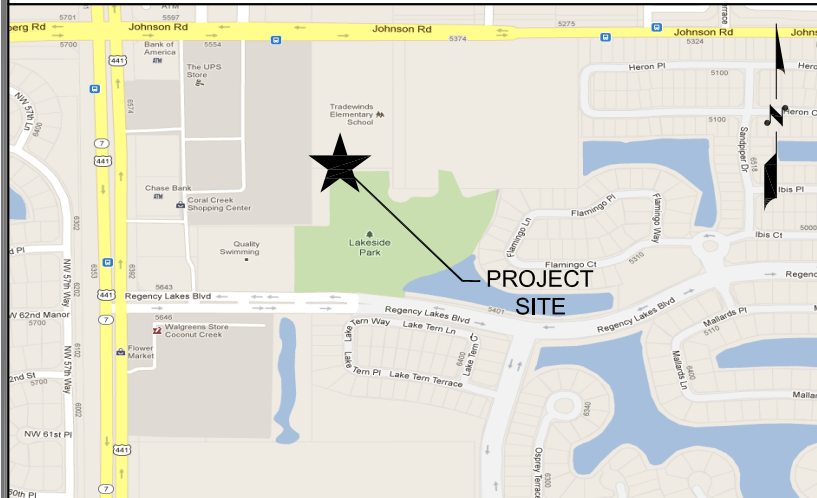

VICINITY MAP

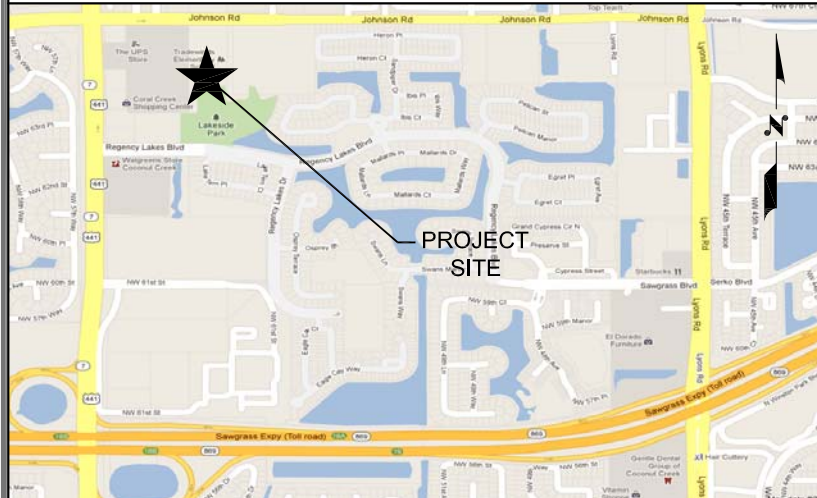

DRIVING DIRECTIONS

FROM T-MOBILE'S OFFICE: HEAD NORTH THEN EAST ON SAWGRASS EXPY N FOR 17.2 MILES TO US-441, HEAD NORTH FOR 1.1 MILES TO REGENCY LAKES BLVD, TURN RIGHT AND HEAD EAST FOR 0.1 MILES TO SITE ON LEFT SIDE OF THE ROAD

SCOPE OF WORK

INSTALLATION OF NEW UNMANNED T-MOBILE TELECOMMUNICATIONS RADIOS WITHIN EXISTING FENCED COMPOUND AND REPLACEMENT OF EXISTING ANTENNAS ON EXISTING TOWER.

PROPERTY SUMMARY

PARCEL #: 4842-06-16-0012
 LATITUDE: 26° 18' 36.20" N
 LONGITUDE: 80° 11' 58.10" W
 ZONING JURISDICTION: CITY OF COCONUT CREEK
 ZONING CLASSIFICATION: RECREATIONAL

LEGAL DESCRIPTION

REGENCY LAKES AT COCONUT CREEK 157-23 B PART OF PARCEL A DESC'D AS COMM AT SW COR TR A OF SAWGRASS PK OF COMMERCE COMM SEC B,E 214.18,S 30,E 426.56 TO POB,E 144.31,N 285.03,E 254.66,S 99.99,E 438.79 TO P/I,SLY & WLY 576.15,WLY & S 147.42,SLY 5.58,WLY 213.60,WLY 200,NLY 330.41 TO POB AKA: PARK SITE-REGENCY LAKES AT COCONUT CREEK

APPLICABLE CODES

ALL WORK AND MATERIALS SHALL BE PERFORMED AND INSTALLED IN ACCORDANCE WITH THE CURRENT CONDITIONS OF THE FOLLOWING CODES AS ADOPTED BY THE LOCAL GOVERNING AUTHORITIES. NOTHING IN THESE PLANS IS TO BE CONSTRUED TO PERMIT WORK NOT CONFORMING TO THESE CODES:

- 2010 FLORIDA BUILDING CODE
WIND DESIGN CRITERIA:
A. ASCE 7-10
BASIC WIND SPEED=170 (ULTIMATE 3-SECOND GUST) MPH
RISK CATEGORY = II
EXPOSURE= C
B. ANSI/ TIA - 222- G
(ALLOWED PER EXEMPTION #5 OF 1609.1, FBC2010)
BASIC WIND SPEED = 132 (NOMINAL 3-SECOND GUST) MPH
OCCUPANCY CATEGORY= II
EXPOSURE= C
IMPORTANCE FACTOR - 1.0
- ASCE 7-10
- ANSI/EIA/TIA-222-G
- FLORIDA FIRE PREVENTION CODE- 2010
- NATIONAL ELECTRICAL CODE (NFPA 70-2008)
- CITY AND/OR COUNTY ORDINANCES

CONTACTS

APPLICANT:
T-MOBILE USA
1300 CONCORD TERRACE
SUITE 200
SUNRISE, FL 33323

PROPERTY OWNER CONTACT:
LANDLORD: CITY OF COCONUT CREEK
ADDRESS: 4800 WEST COPANS ROAD
CITY, STATE, ZIP: COCONUT CREEK, FL 33063

INDEX OF DRAWINGS

SHT. NO.	DESCRIPTION	REV. NO.
T1	COVER SHEET	1
T2	NOTES	0
A1	COMPOUND PLAN	0
A2	EQUIPMENT PLANS	0
A3	ANTENNA LAYOUTS	1
A4	ELEVATION	1
A5	DETAILS	1
E1	ELECTRICAL AND GROUNDING DETAILS	0

APPROVALS

PROPERTY OWNER _____
 RF ENGINEER _____
 CONSTRUCTION _____
 SITE ACQUISITION _____
 ZONING _____
 NETWORK _____
 OPERATIONS _____
 CONTRACTOR _____

ADMINISTRATIVE APPROVAL 11-24-14
APPROVED

APPROVALS

DESIGN BASED ON RFDS VERSION V2.0
 CONTRACTOR SHALL REQUEST
 T-MOBILE FOR CURRENT RFDS PRIOR
 TO CONSTRUCTION

C:\Users\rjlaraz\AppData\Local\Temp\AcPublish_17552\7140041_6FB1173B_LAKE_SIDE_PARK_L700_MHz_CDs_REV_1_10-20-14.dwg 10/20/2014 3:55pm rjlaraz

C:\Users\ralaz\AppData\Local\Temp\AcPublish...17552\7140041_6FB1173B_LAKE SIDE PARK_1700_MHz_CDs_REV_L_10-20-14.dwg 10/20/2014 3:55pm ralaz

ARCHITECTURAL GENERAL NOTES

ELECTRICAL GENERAL NOTES

COMPOUND NOTES

- WORK SHALL COMPLY WITH ALL APPLICABLE CODES, ORDINANCES, AND REGULATIONS. ALL NECESSARY LICENSES, CERTIFICATES, ETC., REQUIRED BY AUTHORITY HAVING JURISDICTION SHALL BE PROCURED AND PAID FOR BY THE CONTRACTOR.
- THE GENERAL CONTRACTOR AND EACH SUBCONTRACTOR SHALL BE RESPONSIBLE FOR VERIFYING DIMENSIONS AND CONDITIONS AT THE JOB SITE WHICH COULD AFFECT THE WORK UNDER THIS CONTRACT. ALL MANUFACTURERS RECOMMENDED SPECIFICATIONS, EXCEPT THOSE SPECIFICATIONS HEREIN, WHERE MOST STRINGENT SHALL BE COMPLIED WITH.
- THE CONTRACTOR SHALL VERIFY THAT NO CONFLICTS EXIST BETWEEN THE LOCATIONS OF ANY AND ALL MECHANICAL, ELECTRICAL, PLUMBING, OR STRUCTURAL ELEMENTS, AND THAT ALL REQUIRED CLEARANCES FOR INSTALLATION AND MAINTENANCE ARE MET. NOTIFY THE CONSULTANT OF ANY CONFLICTS. THE CONSULTANT HAS THE RIGHT TO MAKE MINOR MODIFICATIONS IN THE DESIGN OF THE CONTRACT WITHOUT THE CONTRACTOR GETTING ADDITIONAL COMPENSATION.
- THE CONTRACTOR SHALL BE RESPONSIBLE FOR DAILY CLEAN UP OF ALL TRADES AND REMOVE ALL DEBRIS FROM THE CONSTRUCTION SITE. AT THE COMPLETION OF THE PROJECT, THE CONTRACTOR SHALL THOROUGHLY CLEAN THE BUILDING, SITE, AND ANY OTHER SURROUNDING AREAS TO A BETTER THAN NEW CONDITION.
- THE CONTRACTOR IS RESPONSIBLE FOR ADEQUATELY BRACING AND PROTECTING ALL WORK DURING CONSTRUCTION AGAINST DAMAGE, BREAKAGE, COLLAPSE, ETC. ACCORDING TO APPLICABLE CODES, STANDARDS, AND GOOD CONSTRUCTION PRACTICES.
- WHERE ONE DETAIL IS SHOWN FOR ONE CONDITION, IT SHALL APPLY FOR ALL LIKE OR SIMILAR CONDITIONS, EVEN THOUGH NOT SPECIFICALLY MARKED ON THE DRAWINGS OR REFERRED TO IN THE SPECIFICATIONS, UNLESS NOTED OTHERWISE.
- WHERE NEW PAVING, CONCRETE SIDEWALKS OR PATHS MEET EXISTING CONSTRUCTION, THE CONTRACTOR SHALL MATCH THE EXISTING PITCH, GRADE, AND ELEVATION SO THE ENTIRE STRUCTURE SHALL HAVE A SMOOTH TRANSITION.
- THE GENERAL CONTRACTOR SHALL OBTAIN WRITTEN CONFIRMATION OF THE EXPECTED DATE OF COMPLETION OF THE POWER CONNECTION FROM THE POWER COMPANY.
- IF THE POWER COMPANY IS UNABLE TO PROVIDE THE POWER CONNECTION BY OWNER'S REQUIRED DATE, THE GENERAL CONTRACTOR SHALL PROVIDE AND MAINTAIN A TEMPORARY GENERATOR UNTIL THE POWER COMPANY CONNECTION IS COMPLETED. COSTS ASSOCIATED WITH THE TEMPORARY GENERATOR TO BE APPROVED BY THE OWNER.
- PLANS PART OF THIS SET ARE COMPLEMENTARY. INFORMATION IS NOT LIMITED TO ONE PLAN. DRAWINGS AND SPECIFICATIONS ARE INSTRUMENTS OF SERVICE AND SHALL REMAIN THE PROPERTY OF THE ARCHITECT, WHETHER THE PROJECT FOR WHICH THEY ARE MADE IS EXECUTED OR NOT. THEY ARE NOT TO BE USED BY THE OWNER ON OTHER PROJECTS OR EXTENSION TO THIS PROJECT EXCEPT BY AGREEMENT IN WRITING AND WITH APPROPRIATE COMPENSATION TO MORRISON HERSHFIELD. THESE PLANS WERE PREPARED TO BE SUBMITTED TO GOVERNMENTAL BUILDING AUTHORITIES FOR REVIEW FOR COMPLIANCE WITH APPLICABLE CODES AND IT IS THE SOLE RESPONSIBILITY OF THE OWNER AND/OR CONTRACTOR TO BUILD ACCORDING TO APPLICABLE BUILDING CODES.
- IF CONTRACTOR OR SUB-CONTRACTOR FIND IT NECESSARY TO DEVIATE FROM ORIGINAL APPROVED PLANS, THEN IT IS THE CONTRACTOR'S AND THE SUB-CONTRACTOR'S RESPONSIBILITY TO PROVIDE THE ARCHITECT WITH 4 COPIES OF THE PROPOSED CHANGES FOR HIS APPROVAL BEFORE PROCEEDING WITH THE WORK. IN ADDITION THE CONTRACTOR AND SUB-CONTRACTORS SHALL BE RESPONSIBLE FOR PROCURING ALL NECESSARY APPROVALS FROM THE BUILDING AUTHORITIES FOR THE PROPOSED CHANGES BEFORE PROCEEDING WITH THE WORK. THE CONTRACTOR AND SUB-CONTRACTORS SHALL BE RESPONSIBLE FOR PROCURING ALL NECESSARY INSPECTIONS AND APPROVALS FROM BUILDING AUTHORITIES DURING THE EXECUTION OF THE WORK.
- IN EVERY EVENT, THESE CONSTRUCTION DOCUMENTS AND SPECIFICATIONS SHALL BE INTERPRETED TO BE A MINIMUM ACCEPTABLE MEANS OF CONSTRUCTION BUT THIS SHALL NOT RELIEVE THE CONTRACTOR, SUB-CONTRACTOR, AND/OR SUPPLIER/MANUFACTURER FROM PROVIDING A COMPLETE AND CORRECT JOB WHEN ADDITIONAL ITEMS ARE REQUIRED TO THE MINIMUM SPECIFICATION. IF ANY ITEMS NEED TO EXCEED THESE MINIMUM SPECIFICATIONS TO PROVIDE A COMPLETE, ADEQUATE AND SAFE WORKING CONDITION, THEN IT SHALL BE THE DEEMED AND UNDERSTOOD TO BE INCLUDED IN THE DRAWINGS. FOR EXAMPLE, IF AN ITEM AND/OR PIECE OF EQUIPMENT REQUIRES A LARGER WIRE SIZE (I.E. ELECTRICAL WIRE), STRONGER OR LARGER PIPING, INCREASED QUANTITY (I.E. STRUCTURAL ELEMENTS), REDUCED SPACING, AND/OR INCREASED LENGTH (I.E. BOLT LENGTHS, BAR LENGTHS) THEN IT SHALL BE DEEMED AND UNDERSTOOD TO BE INCLUDED IN THE BID/PROPOSAL. THESE DOCUMENTS ARE MEANT AS A GUIDE AND ALL ITEMS REASONABLY INFERRED SHALL BE DEEMED TO BE INCLUDED.
- THESE CONTRACT DOCUMENTS AND SPECIFICATIONS SHALL NOT BE CONSTRUED TO CREATE A CONTRACTUAL RELATIONSHIP OF ANY KIND BETWEEN THE ARCHITECT AND THE CONTRACTOR.

- A. GENERAL**
- EXAMINE THE SITE CONDITIONS VERY CAREFULLY AND THE SCOPE OF PROPOSED WORK TOGETHER WITH THE WORK OF ALL OTHER TRADES AND INCLUDE IN THE BID PRICE ALL COSTS FOR WORK SUCH AS EQUIPMENT AND WIRING MADE NECESSARY TO ACCOMMODATE THE ELECTRICAL SYSTEMS SHOWN AND SYSTEMS OF OTHER TRADES.
 - OBTAIN ALL PERMITS, PAY ASSOCIATED FEES AND SCHEDULE INSPECTION.
 - PROVIDE ALL LABOR, MATERIAL, EQUIPMENT, INSURANCE, AND SERVICES TO COMPLETE THIS PROJECT IN ACCORDANCE WITH THE CONTRACT DOCUMENTS AND PRESENT IT AS FULLY OPERATIONAL TO THE SATISFACTION OF METRO-PCS & LAND/TOWER OWNER
 - PRIOR TO BEGINNING WORK COORDINATE ALL POWER AND TELCO WORK WITH THE LOCAL UTILITY COMPANY AS IT MAY APPLY TO THIS SITE. ALL WORK TO COMPLY WITH THE RULES AND REGULATIONS OF THE UTILITIES INVOLVED GENERAL CONTRACTOR IS RESPONSIBLE FOR VED. REQUESTING CONNECTION OF COMMERCIAL POWER FROM THE POWER COMPANY. ELECTRICAL CONTRACTOR SHALL COORDINATE THIS WORK WITH THE GENERAL CONTRACTOR.
 - FABRICATION AND INSTALLATION OF THE COMPLETE ELECTRICAL SYSTEM SHALL BE DONE IN A FIRST CLASS WORKMANSHIP PER NECA STANDARD 1-2000 BY QUALIFIED PERSONNEL EXPERIENCED IN SUCH WORK AND SHALL SCHEDULE THE WORK IN AN ORDERLY MANNER SO AS NOT TO IMPEDE PROGRESS OF THE PROJECT.
- B. BASIC MATERIALS AND METHODS**
- ALL ELECTRICAL WORK SHALL CONFORM TO THE EDITION OF THE NEC ACCEPTED BY THE LOCAL JURISDICTION AND TO THE APPLICABLE LOCAL CODES AND REGULATIONS.
 - ARRANGE CONDUIT, WIRING, EQUIPMENT, AND OTHER WORK GENERALLY AS SHOWN, PROVIDING PROPER CLEARANCES AND ACCESS. CAREFULLY EXAMINE ALL CONTRACT DRAWINGS AND FIT THE WORK IN EACH LOCATION WITHOUT SUBSTANTIAL ALTERATION. WHERE DEPARTURES ARE PROPOSED BECAUSE OF FIELD CONDITIONS OR OTHER CAUSES, PREPARE AND SUBMIT DETAILED DRAWINGS FOR ACCEPTANCE.
 - THE CONTRACT DRAWINGS ARE GENERALLY DIAGRAMMATIC AND ALL OFFSETS, BENDS, FITTINGS AND ACCESSORIES ARE NOT NECESSARILY SHOWN. PROVIDE ALL SUCH ITEMS AS MAY BE REQUIRED TO FIT THE WORK TO THE CONDITIONS.
 - SEAL AROUND CONDUITS AND AROUND CONDUCTORS WITHIN CONDUITS ENTERING THE MODULAR CABINETS WHERE PENETRATION OCCURS WITH A SILICONE SEALANT TO PREVENT MOISTURE PENETRATION INTO BUILDING.
- C. CONDUCTORS AND CONNECTORS**
- UNLESS NOTED OTHERWISE, ALL CONDUCTORS SHALL BE COPPER, MINIMUM SIZE #12 AWG, WITH THERMOPLASTIC INSULATION CONFORMING TO NEMA WC5 OR CROSS-LINKED POLYETHYLENE INSULATION CONFORMING TO NEMA WC7. (TYPES THHN). INSULATION SHALL BE RATED FOR 90 DEG. CONDUCTORS SHALL BE COLOR CODED IN ACCORDANCE WITH NEC.
 - CONDUCTOR LENGTHS SHALL BE CONTINUOUS FROM TERMINATION TO TERMINATION WITHOUT SPLICES. SPLICES ARE NOT ACCEPTABLE. IF SPLICES ARE UNAVOIDABLE PRIOR APPROVAL FROM THE ENGINEER MUST BE OBTAINED.
- D. GROUNDING**
- ALL LIGHTNING PROTECTION GROUNDING OF THE ELECTRICAL EQUIPMENT SHALL BE CARRIED OUT IN ACCORDANCE WITH THE CURRENT NFPA STANDARDS.
 - ALL GROUND LUG AND COMPRESSION CONNECTIONS SHALL BE COATED WITH ANTI-OXIDANT AGENT, SUCH AS NO-OX, NOALOX, PENETROX OR KOPRSHIELD.
 - ALL EXTERIOR GROUNDING CONDUCTORS INCLUDING EXTERIOR GROUND RING SHALL BE #2 AWG SOLID BARE TINNED COPPER. MAKE ALL GROUND CONNECTIONS AS SHORT AND DIRECT AS POSSIBLE. AVOID SHARP BENDS. THE RADIUS OF ANY BEND SHALL NOT BE LESS THAN 8" AND THE ANGLE OF ANY BEND SHALL NOT EXCEED 90°. GROUNDING CONDUCTORS SHALL BE ROUTED DOWNWARD TOWARD THE BURIED GROUND RING.
 - REPAIR ALL GALVANIZED SURFACES THAT HAVE BEEN DAMAGED BY THERMO-WELDING WITH ERICO T-319 GALVANIZING BAR.
 - ALL EXTERNAL GROUND CONNECTIONS SHALL BE EXOTHERMICALLY WELDED. ALL EXOTHERMIC WELDS TO EXTERIOR GROUND RING SHALL BE THE PARALLEL TYPE, EXCEPT FOR THE GROUND RODS WHICH ARE TEE EXOTHERMIC WELDS. REPAIR ALL GALVANIZED SURFACES THAT HAVE BEEN DAMAGED BY EXOTHERMIC WELDING. USE SPRAY GALVANIZER SUCH AS HOLUB LECTROSOL #15-501.

- THE MINIMUM LOWEST FIRST FLOOR ELEVATION SHALL NOT BE LESS THAN 4" ABOVE CROWN OF ROAD OR THE FEDERAL AND/OR COUNTY FLOOD CRITERIA ELEVATION, WHICHEVER IS HIGHER. CONTRACTOR SHALL SUBMIT AN ELEVATION CERTIFICATE (IF REQUIRE BY THE JURISDICTION) UPON COMPLETION OF PROJECT.
- WORK OUTSIDE OF THE PROPERTY LINE INCLUDED IN THIS SET OF DRAWINGS SHALL BE, BUT NOT LIMITED TO, DRIVEWAYS, SODDING TO ASPHALT LINE AND UTILITY CONNECTIONS.
- EXISTING TREES WITHIN CONSTRUCTION FOOTPRINT SHALL BE REMOVED AND PROPERLY DISPOSED OF. CONTRACTOR SHALL PROCURE PERMIT PRIOR TO REMOVAL.
- CONTRACTOR AND SUBCONTRACTORS SHALL VERIFY ALL UTILITY SERVICE CONNECTION LOCATIONS PRIOR TO SUBMITTING BID AND PROCEEDING WITH WORK. IT IS RECOMMENDED THAT THE CONTRACTOR VISIT THE SITE AND VERIFY ALL DIMENSIONS AND NOTES BEFORE SUBMITTING BID AND PROCEEDING WITH WORK.
- SOIL AT THIS SITE IS UNDISTURBED ROCK AND SAND ADEQUATE OF SUPPORTING THE DESIGN LOAD OF 2000 P.S.F. IF OTHER CONDITIONS ARE ENCOUNTERED, NOTIFY MIRRISON HERSHFIELD BEFORE PROCEEDING WITH WORK. THIS VALUE IS CONSIDERED SAFE WITH RESPECT TO ACTUAL FAILURE OF THE SUPPORTING GROUND, BUT DOES NOT NECESSARILY ENSURE THE PREVENTION OF EXCESSIVE FOUNDATION MOVEMENTS.
- BURY PHONE, AND ELECTRIC SERVICE NO LESS THAN 24" BELOW FINISH GRADE WITH 1'-0" RADIUS SAND BACKFILL AROUND PIPES. COORDINATE W/ ELECTRICAL DRAWINGS.
- IN ORDER TO AVOID ANY CONFLICTS, CONTRACTOR SHALL COORDINATE ALL HIS PRACTICAL TRADES.
- THE POWER CABINET MUST BE CLEAR OF FLAMMABLE MATERIAL WITHIN 12 INCHES OF THE CABINET, INCLUDING ABOVE THE CABINET.
- EXHAUST OUTLETS MUST BE LOCATED AT LEAST 10 FEET FROM ANY HVAC AIR INTAKES, WINDOWS, DOORS, AND OTHER OPENINGS INTO A BUILDING - COORDINATE IN FIELD.
- THE POWER CABINET MUST BE MOUNTED ON THE FOUNDATION TO ALLOW WATER TO DRAIN FROM THE DRAIN OUTLET AND AWAY FROM THE CABINET.
- TO ENSURE SERVICEABLE ABILITY, THE DOORS OF CABINETS WILL REQUIRE AN OPENING RADIUS OF 36 INCHES OF CLEARANCE FROM THE CLOSED POSITION TO THE OPEN POSITION.

IMPORTANT NOTICE

PROJECT INFORMATION

SITE GENERAL NOTES

THE EXISTING CONDITIONS REPRESENTED HEREIN ARE BASED ON VISUAL OBSERVATIONS AND INFORMATION PROVIDED BY OTHERS. MORRISON HERSHFIELD CORPORATION CANNOT GUARANTEE THE CORRECTNESS NOR COMPLETENESS OF THE EXISTING CONDITIONS SHOWN AND ASSUMES NO RESPONSIBILITY THEREOF. CONTRACTOR AND HIS SUB-CONTRACTORS SHALL VISIT THE SITE AND VERIFY ALL EXISTING CONDITIONS AS REQUIRED FOR PROPER EXECUTION OF PROJECT. REPORT ANY CONFLICTS OR DISCREPANCIES TO THE CONSULTANT PRIOR TO CONSTRUCTION.

- THIS IS AN UNMANNED AND RESTRICTED ACCESS EQUIPMENT AND WILL BE USED FOR THE TRANSMISSION OF RADIO SIGNALS FOR THE PURPOSE OF PROVIDING PUBLIC CELLULAR SERVICE.
- THIS FACILITY WILL CONSUME NO UNRECOVERABLE ENERGY AND IS EXEMPT FROM THE FLORIDA ENERGY REVIEW CODE.
- NO POTABLE WATER SUPPLY IS TO BE PROVIDED AT THIS LOCATION.
- NO WASTE WATER WILL BE GENERATED AT THIS LOCATION.
- NO SOLID WASTE WILL BE GENERATED AT THIS LOCATION.
- T-MOBILE** MAINTENANCE CREW (TYPICALLY ONE PERSON) WILL MAKE AN AVERAGE OF ONE TRIP PER MONTH AT ONE HOUR PER VISIT.

- RESTORE EXISTING ASPHALT AND/OR CONCRETE COMPOUND TO IT'S ORIGINAL CONDITION
- CONTRACTOR SHALL DETECT AND MARK ANY UNDERGROUND LINES, PIPING, PRIOR TO START OF EXCAVATION

DO NOT SCALE DRAWINGS. CONTRACTOR MUST VERIFY ALL DIMENSIONS AND ADVISE CONSULTANTS OF ANY ERRORS OR OMISSIONS. NO VARIATIONS OR MODIFICATIONS TO WORK SHOWN SHALL BE IMPLEMENTED WITHOUT PRIOR WRITTEN APPROVAL. ALL PREVIOUS ISSUES OF THIS DRAWING ARE SUPERSEDED BY THE LATEST REVISION. ALL DRAWINGS AND SPECIFICATIONS REMAIN THE PROPERTY OF MORRISON HERSHFIELD CORPORATION. NEITHER MORRISON HERSHFIELD NOR THE ARCHITECT WILL BE PROVIDING CONSTRUCTION REVIEW OF THIS PROJECT.

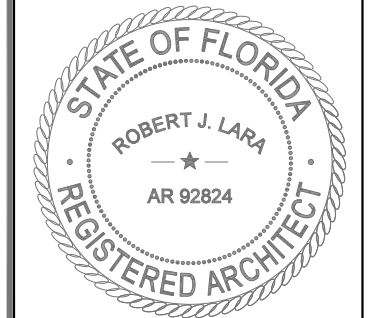

ROBERT JERRY LARA
REGISTERED ARCHITECT
STATE OF FLORIDA
AR92824

5		
4	.	.
3	.	.
2	.	.
1	.	.
0	09/11/14	ISSUE FOR PERMIT
B	08/12/14	PER CLIENT COMMENTS
A	07/11/14	90% CD SUBMITAL
No.	Date	Action

Client:

T-Mobile

stick together

1300 CONCORD TERRACE
SUITE 200
SUNRISE, FL. 33323

Consultant:

M

MORRISON HERSHFIELD
Two South University Drive, Suite 245,
Plantation, FL 33324
Tel: 954.577.4655 Fax: 954.577.4656
FL C OF A #8508
FL Architect business # AA26002368
www.morrisonhershfield.com

Project:

LAKE SIDE PARK
6FB1173B
5555 REGENCY BOULEVARD
COCONUT CREEK, FL 33073

NOTES

Project No.: 7140041	
Designer: CT	Date: 07/10/14
Drawn By: XL	Checked By: RL
PM Review: LP	Client Approval
Issue No.: 0	Drawing No.: T-2

DO NOT SCALE DRAWINGS. CONTRACTOR MUST VERIFY ALL DIMENSIONS AND ADVISE CONSULTANTS OF ANY ERRORS OR OMISSIONS. NO VARIATIONS OR MODIFICATIONS TO WORK SHOWN SHALL BE IMPLEMENTED WITHOUT PRIOR WRITTEN APPROVAL. ALL PREVIOUS ISSUES OF THIS DRAWING ARE SUPERSEDED BY THE LATEST REVISION. ALL DRAWINGS AND SPECIFICATIONS REMAIN THE PROPERTY OF MORRISON HERSHFIELD CORPORATION. NEITHER MORRISON HERSHFIELD NOR THE ARCHITECT WILL BE PROVIDING CONSTRUCTION REVIEW OF THIS PROJECT.

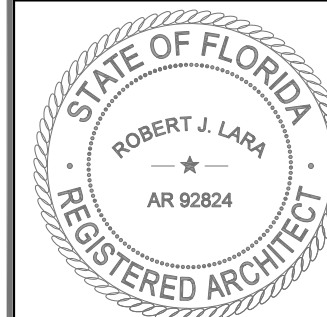

ROBERT JERRY LARA
REGISTERED ARCHITECT
STATE OF FLORIDA
AR92824

5		
4	.	.
3	.	.
2	.	.
1	.	.
0	09/11/14	ISSUE FOR PERMIT
B	08/12/14	PER CLIENT COMMENTS
A	07/11/14	90% CD SUBMITAL
No.	Date	Action

Client:

T-Mobile
stick together[®]

1300 CONCORD TERRACE
SUITE 200
SUNRISE, FL. 33323

Consultant:

M
MORRISON HERSHFIELD
Two South University Drive, Suite 245,
Plantation, FL 33324
Tel: 954.577.4655 Fax: 954.577.4656
FL C OF A #8508
FL Architect business # AA26002368
www.morrisonhershfield.com

Project:

LAKE SIDE PARK
6FB1173B
5555 REGENCY BOULEVARD
COCONUT CREEK, FL 33073

Drawing Title:

COMPOUND PLAN

Project No.:

7140041

Designer:

CT

Date:

07/10/14

Drawn By:

XL

Checked By:

RL

PM Review:

LP

Client Approval

Issue No.:

0

Drawing No.

A-1

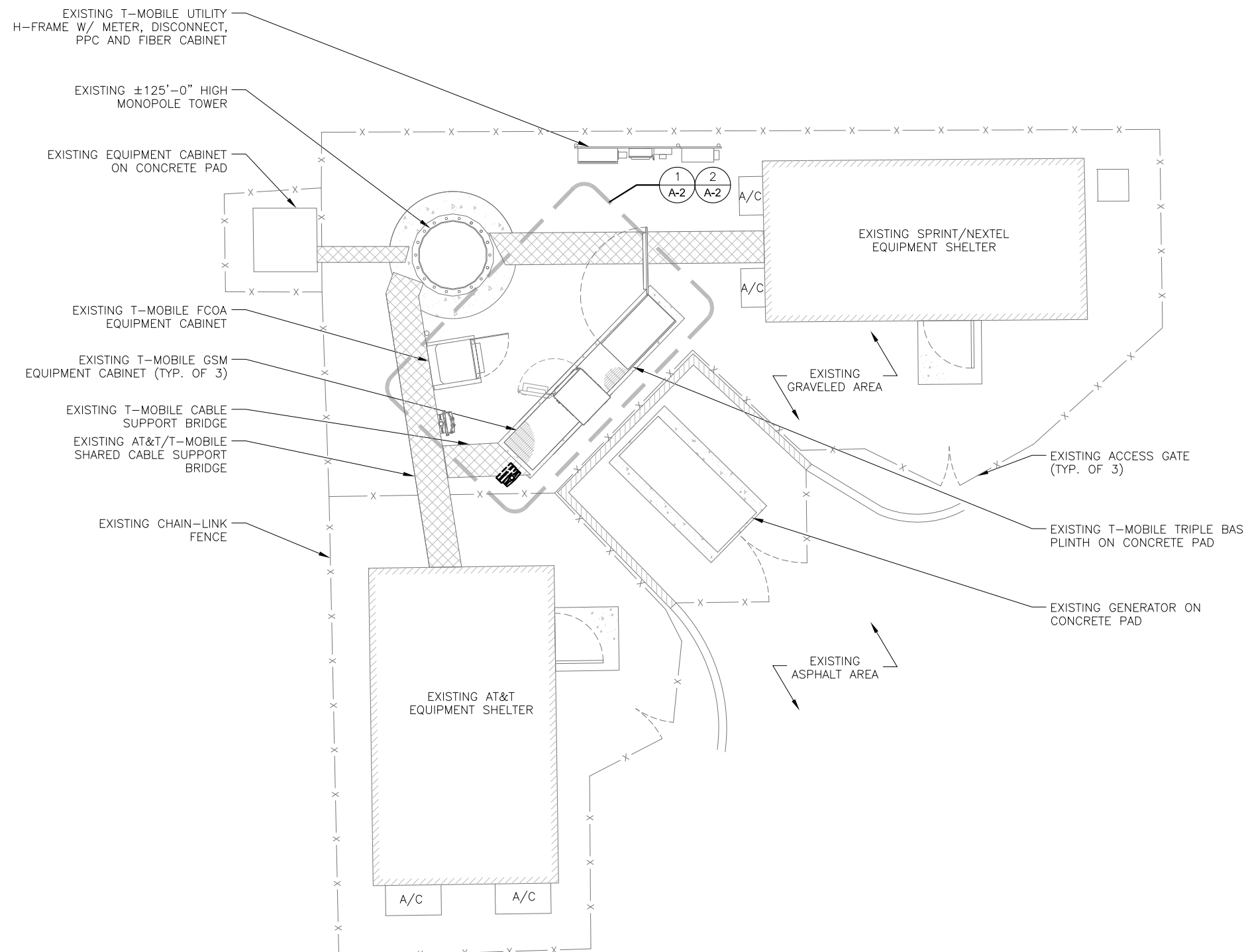

NOTE:
PLAN INFORMATION CONTAINED HEREIN IS TAKEN FROM THE DOCUMENTS PROVIDED BY CLIENT. NEITHER WARRANTY NOR GUARANTEE IS GIVEN BY THE ARCHITECT NOR MORRISON HERSHFIELD CORPORATION TO THE ACCURACY NOR THE COMPLETENESS OF THE COPIED COMPOUND PLAN INFORMATION.



24"x36" SCALE: 1/4" = 1'-0"
11"x17" SCALE: 1/8" = 1'-0"
4' 3' 2' 1' 0" 4'

C:\Users\rjlaraz\AppData\Local\Temp\AcPublish_17552\7140041_6FB1173B_LAKE_SIDE_PARK_L700_MHz_CDs_REV_1_10-20-14.dwg 10/20/2014 3:55pm rjlaraz

COMPOUND PLAN

1 2 3 4 5 6

SCALE IS BASE ON 22" X 34" D" SIZE

DO NOT SCALE DRAWINGS. CONTRACTOR MUST VERIFY ALL DIMENSIONS AND ADVISE CONSULTANTS OF ANY ERRORS OR OMISSIONS. NO VARIATIONS OR MODIFICATIONS TO WORK SHOWN SHALL BE IMPLEMENTED WITHOUT PRIOR WRITTEN APPROVAL. ALL PREVIOUS ISSUES OF THIS DRAWING ARE SUPERSEDED BY THE LATEST REVISION. ALL DRAWINGS AND SPECIFICATIONS REMAIN THE PROPERTY OF MORRISON HERSHFIELD CORPORATION. NEITHER MORRISON HERSHFIELD NOR THE ARCHITECT WILL BE PROVIDING CONSTRUCTION REVIEW OF THIS PROJECT.

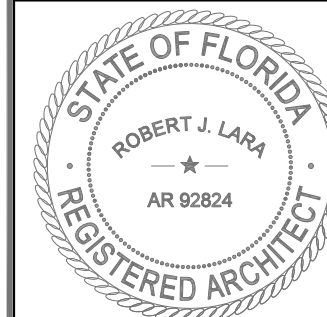

ROBERT JERRY LARA
REGISTERED ARCHITECT
STATE OF FLORIDA
AR92824

5		
4	.	.
3	.	.
2	.	.
1	.	.
0	09/11/14	ISSUE FOR PERMIT
B	08/12/14	PER CLIENT COMMENTS
A	07/11/14	90% CD SUBMITTAL
No.	Date	Action

Client:
T-Mobile
stick together
1300 CONCORD TERRACE
SUITE 200
SUNRISE, FL. 33323

Consultant:
MORRISON HERSHFIELD
Two South University Drive, Suite 245,
Plantation, FL 33324
Tel: 954.577.4655 Fax: 954.577.4656
FL C OF A #8508
FL Architect business # AA26002368
www.morrisonhershfield.com

Project:
**LAKE SIDE PARK
6FB1173B
5555 REGENCY BOULEVARD
COCONUT CREEK, FL 33073**

Drawing Title:
EQUIPMENT PLANS

Project No.: 7140041	
Designer: CT	Date: 07/10/14
Drawn By: XL	Checked By: RL
PM Review: LP	Client Approval
Issue No.: 0	Drawing No.: A-2

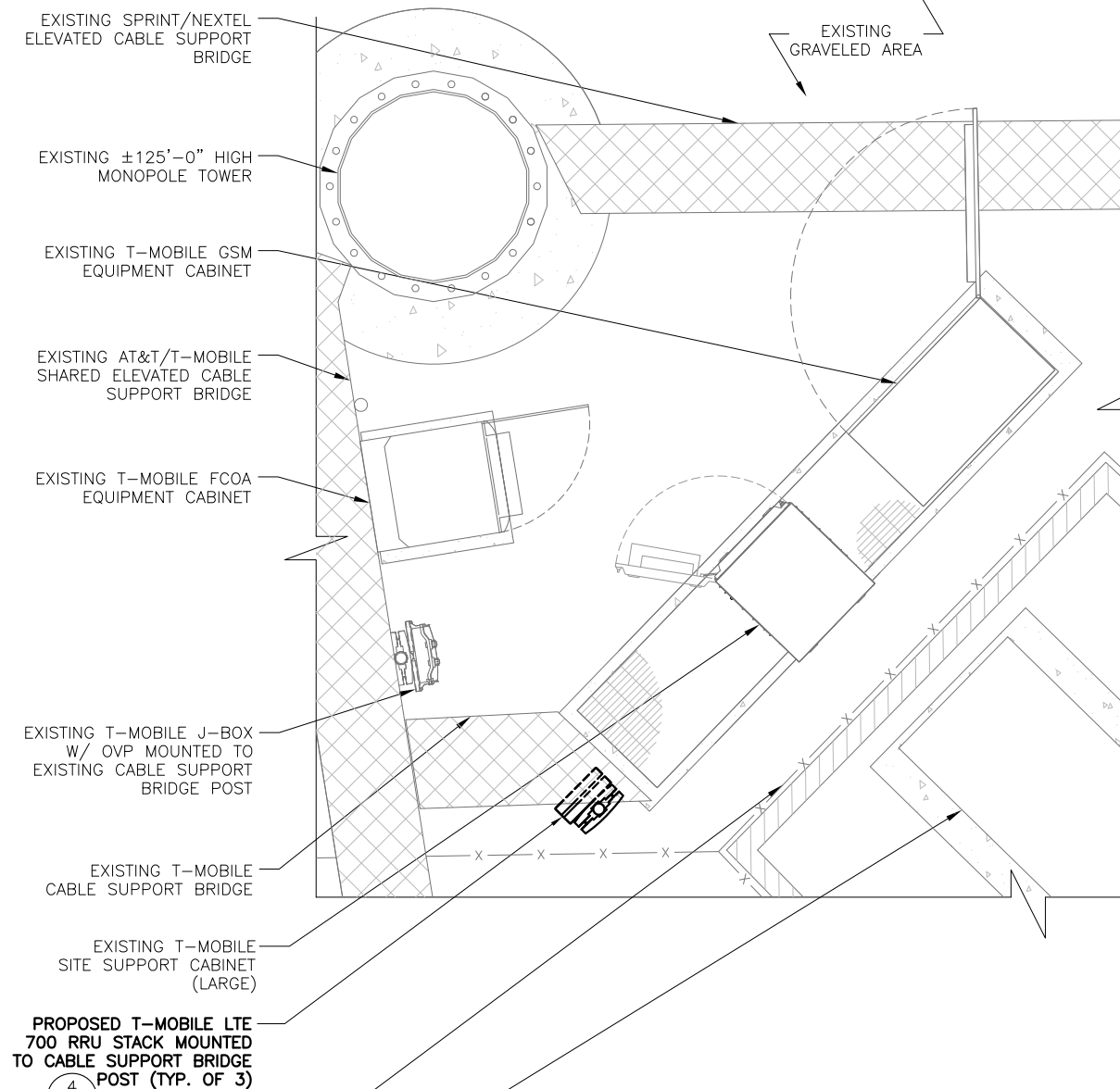
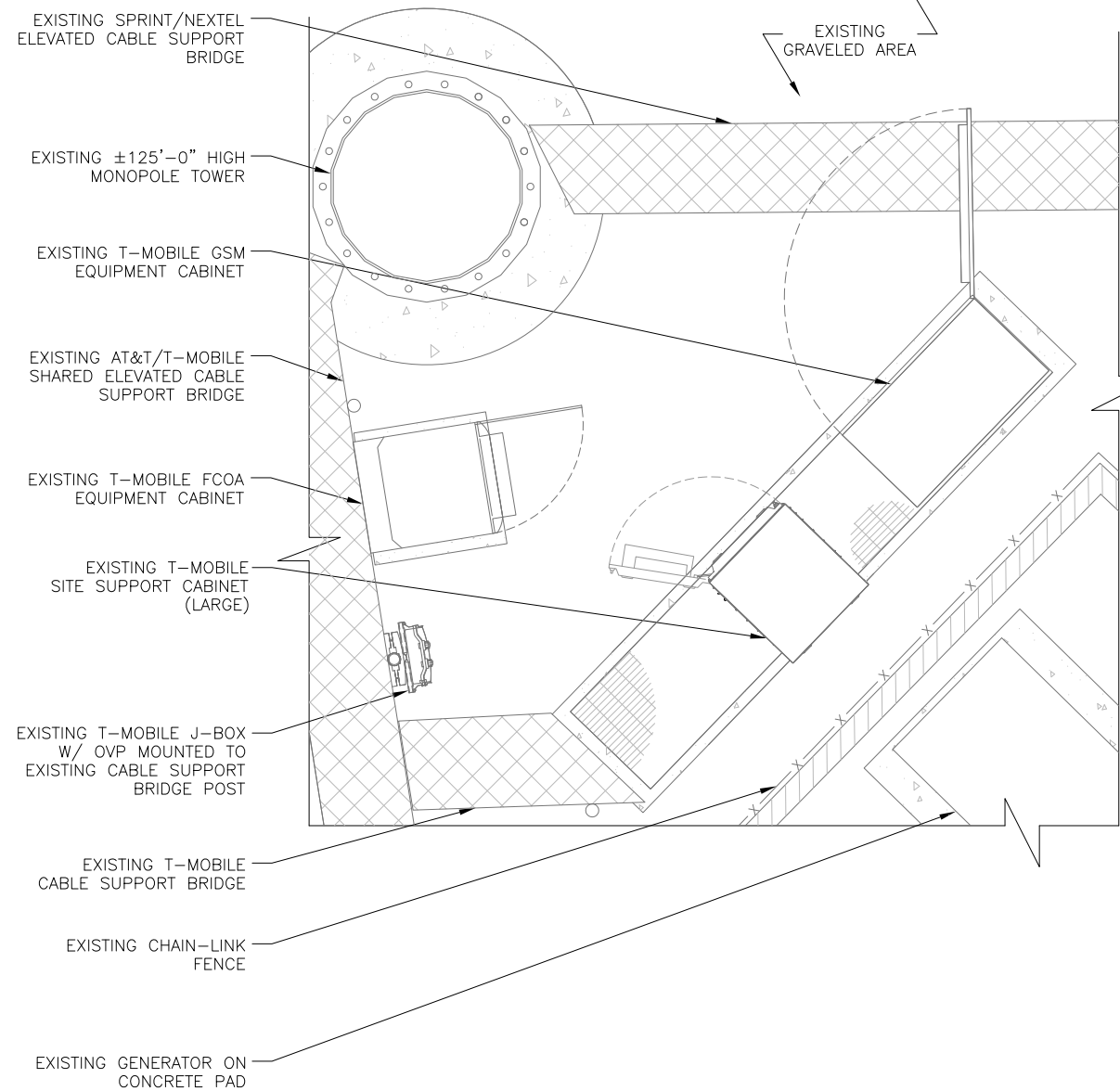

C:\Users\rlara\appdata\local\temp\AcPublish_17552\7140041_6FB1173B_LAKE_SIDE_PARK_L700_MHz_CDs_REV_1_10-20-14.dwg 10/20/2014 3:55pm rlaraz

EXISTING EQUIPMENT PLAN

24"x36" SCALE: 1/2" = 1'-0"
11"x17" SCALE: 1/4" = 1'-0"
1

PROPOSED EQUIPMENT PLAN

24"x36" SCALE: 1/2" = 1'-0"
11"x17" SCALE: 1/4" = 1'-0"
2

1 2 3 4 5 6

SCALE IS BASE ON 22" X 34" D" SIZE

C:\Users\rlalaz\appdata\local\temp\AcPublish_17552\7140041_6FB1173B_LAKE_SIDE_PARK_1700_MHz_CDs_REV_1_10-20-14.dwg 10/20/2014 3:55pm rlalaz

NOTE:
 NO WORK SHALL COMMENCE WITHOUT THE APPROVED ANTENNA MOUNT STRUCTURAL ANALYSIS REPORT SIGNED AND SEALED BY A LICENSED PROFESSIONAL ENGINEER UNDER SEPARATE COVER. IF REQUIRED, THE CONTRACTOR SHALL MODIFY TOWER AND/OR ANTENNA MOUNTS AS INDICATED IN THE ABOVE MENTIONED STRUCTURAL REPORT OR ASSOCIATED MODIFICATION DESIGN DRAWINGS.

DO NOT SCALE DRAWINGS. CONTRACTOR MUST VERIFY ALL DIMENSIONS AND ADVISE CONSULTANTS OF ANY ERRORS OR OMISSIONS. NO VARIATIONS OR MODIFICATIONS TO WORK SHOWN SHALL BE IMPLEMENTED WITHOUT PRIOR WRITTEN APPROVAL. ALL PREVIOUS ISSUES OF THIS DRAWING ARE SUPERSEDED BY THE LATEST REVISION. ALL DRAWINGS AND SPECIFICATIONS REMAIN THE PROPERTY OF MORRISON HERSHFIELD CORPORATION. NEITHER MORRISON HERSHFIELD NOR THE ARCHITECT WILL BE PROVIDING CONSTRUCTION REVIEW OF THIS PROJECT.

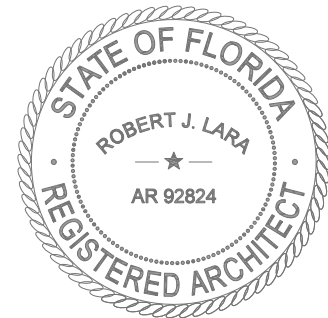

ROBERT JERRY LARA
 REGISTERED ARCHITECT
 STATE OF FLORIDA
 AR92824

5		
4		
3		
2		
1	10/20/14	RE-ISSUED FOR PERMIT
0	09/11/14	ISSUE FOR PERMIT
B	08/12/14	PER CLIENT COMMENTS
A	07/11/14	90% CD SUBMITAL
No.	Date	Action

Client:

stick together

1300 CONCORD TERRACE
 SUITE 200
 SUNRISE, FL. 33323

Consultant:

MORRISON HERSHFIELD
 Two South University Drive, Suite 245,
 Plantation, FL 33324
 Tel: 954.577.4655 Fax: 954.577.4656
 FL C OF A #8508
 FL Architect business # AA26002368
 www.morrisonhershfield.com

Project:

LAKE SIDE PARK
 6FB1173B
 5555 REGENCY BOULEVARD
 COCONUT CREEK, FL 33073

Drawing Title:

ANTENNA LAYOUTS

Project No.: 7140041	
Designer: CT	Date: 07/10/14
Drawn By: XL	Checked By: RL
PM Review: LP	Client Approval
Issue No.: 1	Drawing No.: A-3

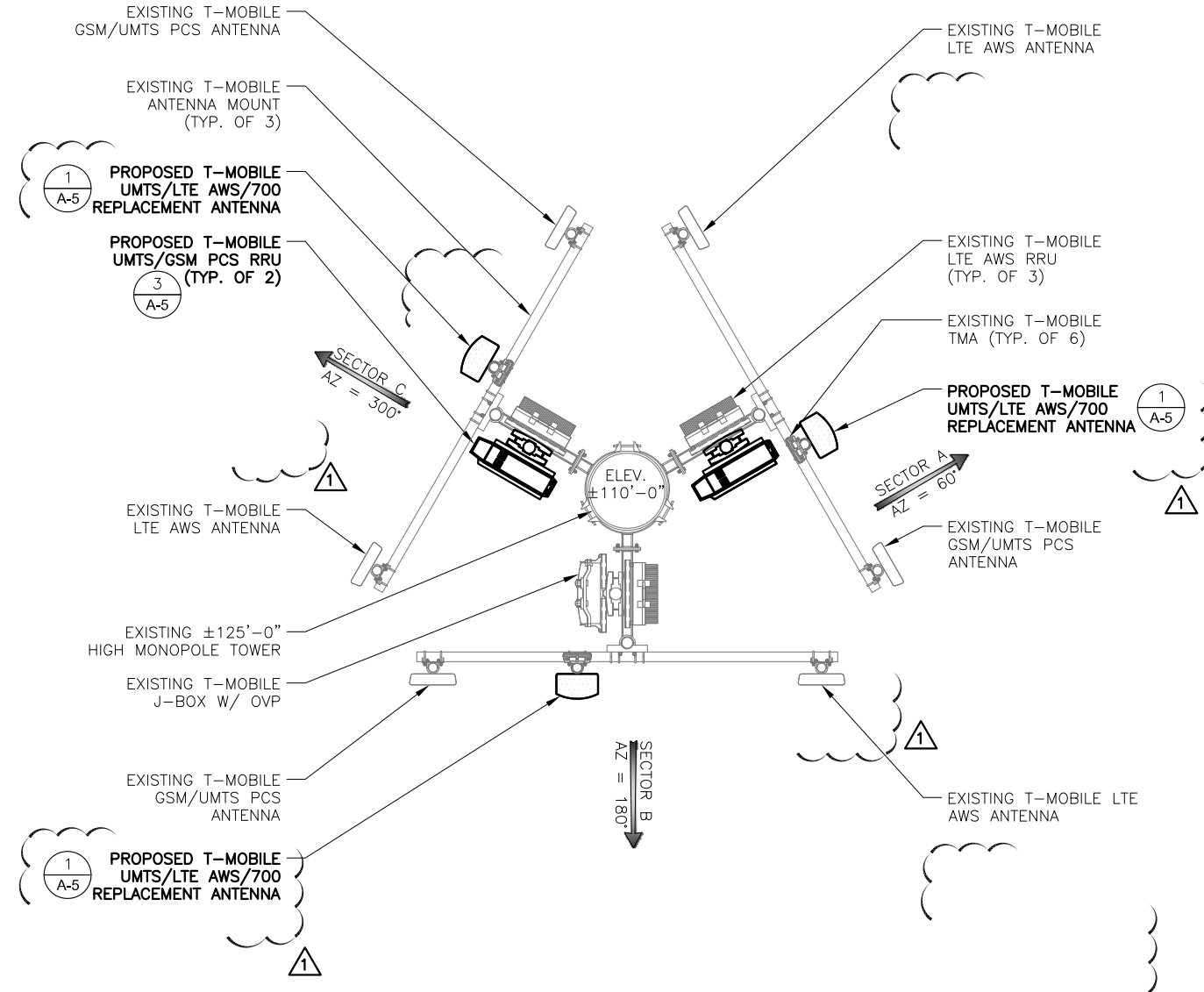
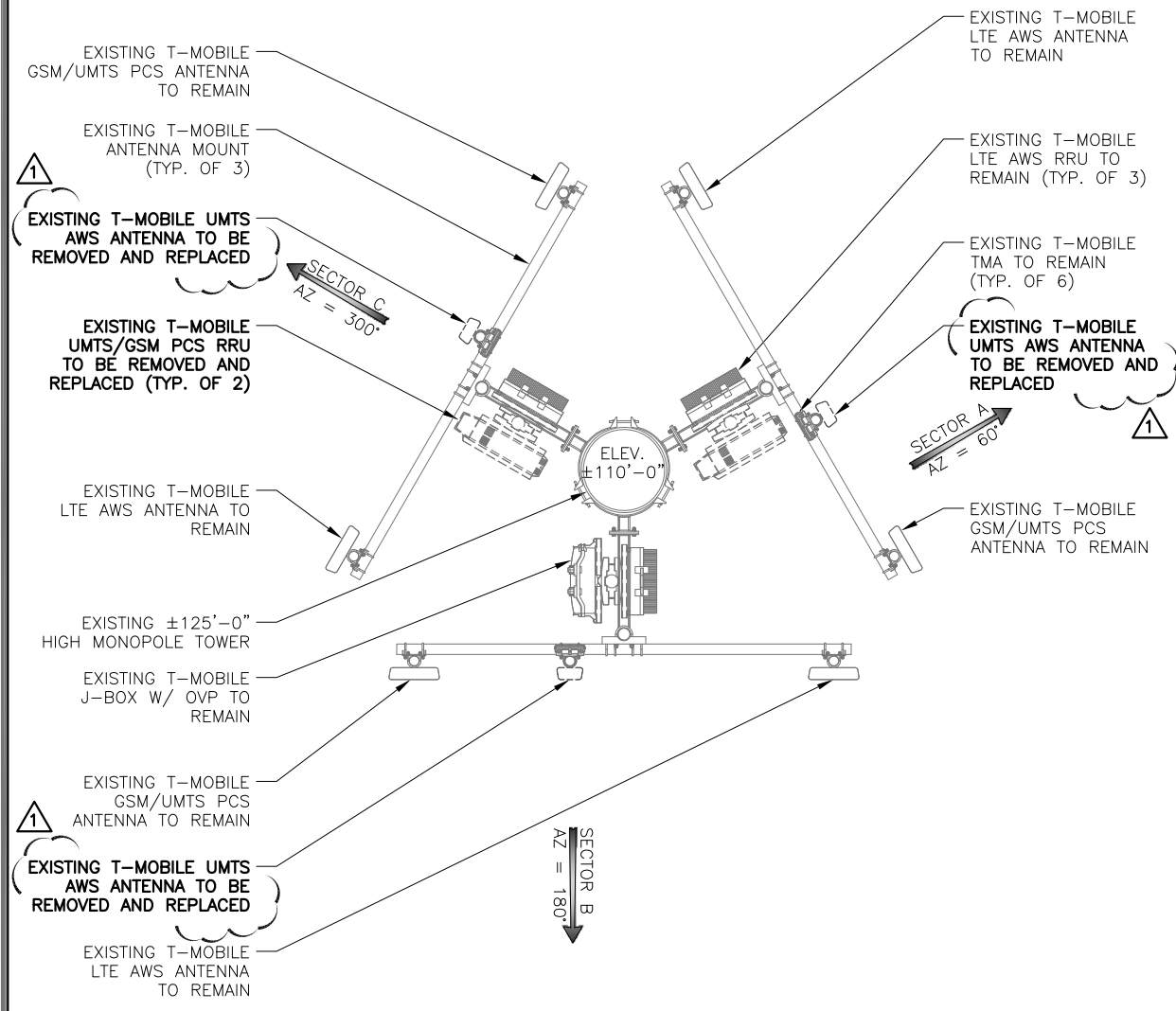

RRUs AND COVP FINAL COUNT				
ITEM	EXISTING	PROPOSED	REMOVED	FINAL COUNT
J-BOX W/ COVP	1	0	0	1
LTE AWS RRU	3	0	0	3
UMTS PCS RRU	2	2	2	2
TWIN PCS TMA	6	0	0	6

EXISTING ANTENNA LAYOUT (SECTORS A, B & C) 24"x36" SCALE: 1/2" = 1'-0" 11"x17" SCALE: 1/4" = 1'-0" 1

PROPOSED ANTENNA LAYOUT (SECTORS A, B & C) 24"x36" SCALE: 1/2" = 1'-0" 11"x17" SCALE: 1/4" = 1'-0" 2

SCALE IS BASE ON 22" X 34" D" SIZE

C:\Users\rlaz\appdata\local\temp\AcPublish_17552\7140041_6FB1173B_LAKE_SIDE_PARK_1700_MHz_SIDE_CDs_REV_1_10-20-14.dwg 10/20/2014 3:55pm rlaz

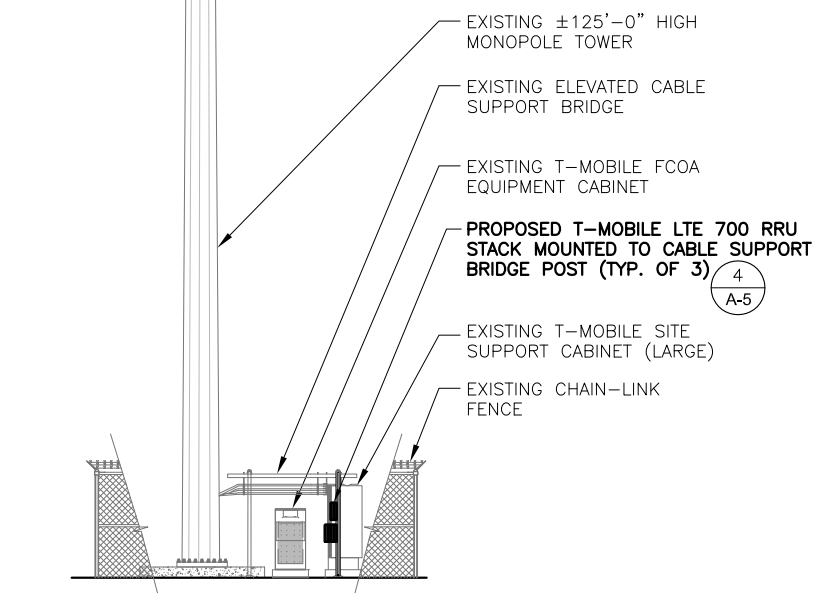
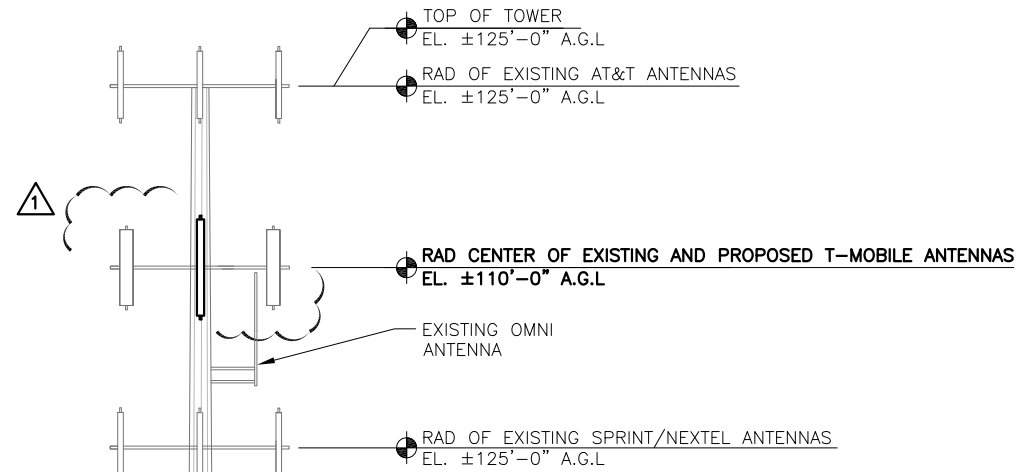

FINAL EQUIPMENT INVENTORY	
ANTENNAS	
(E) (6) RFS APX17DW-17DWVS-A20	1
(N) (3) ANDREW DBXNH-6565B-A2M	
REMOTE RADIO	
(E) (3) NOKIA FRIG W/O SOLAR SHIELD	
(N) (2) NOKIA REPLACEMENT FXFC W/ SOLAR SHIELD	
(N) (3) NOKIA FRLB W/ SOLAR SHIELD (AT GROUND)	
TOWER MOUNTED AMPLIFIERS	
(E) (6) RFS DUAL ATMAP1412D-1A20	
CABLES	
(E) (1) 1.24" LOW CAPACITY HCS	
(E) (12) 7/8" COAX	
(1) COMMScope 1.3" C4006L-NFNF	
JUNCTION BOXES	
(E) (1) RAYCAP ASU9338TYP01 COVP (AT TOWER)	
(E) (1) RAYCAP ASU9338TYP01 COVP (AT GROUND)	

NOTE: E = EXISTING
N = NEW

NOTE:
PLAN INFORMATION CONTAINED HEREIN IS TAKEN FROM THE DOCUMENTS PROVIDED BY CLIENT. NEITHER WARRANTY NOR GUARANTEE IS GIVEN BY THE ARCHITECT NOR MORRISON HERSHFIELD CORPORATION TO THE ACCURACY NOR THE COMPLETENESS OF THE COPIED ELEVATION INFORMATION.

NOTE:
NO WORK SHALL COMMENCE WITHOUT THE APPROVED TOWER/ANTENNA MOUNT STRUCTURAL ANALYSIS REPORT SIGNED AND SEALED BY A LICENSED PROFESSIONAL ENGINEER UNDER SEPARATE COVER. IF REQUIRED, THE CONTRACTOR SHALL MODIFY TOWER AND/OR ANTENNA MOUNTS AS INDICATED IN THE ABOVE MENTIONED STRUCTURAL REPORT OR ASSOCIATED MODIFICATION DESIGN DRAWINGS.

DO NOT SCALE DRAWINGS. CONTRACTOR MUST VERIFY ALL DIMENSIONS AND ADVISE CONSULTANTS OF ANY ERRORS OR OMISSIONS. NO VARIATIONS OR MODIFICATIONS TO WORK SHOWN SHALL BE IMPLEMENTED WITHOUT PRIOR WRITTEN APPROVAL. ALL PREVIOUS ISSUES OF THIS DRAWING ARE SUPERSEDED BY THE LATEST REVISION. ALL DRAWINGS AND SPECIFICATIONS REMAIN THE PROPERTY OF MORRISON HERSHFIELD CORPORATION. NEITHER MORRISON HERSHFIELD NOR THE ARCHITECT WILL BE PROVIDING CONSTRUCTION REVIEW OF THIS PROJECT.

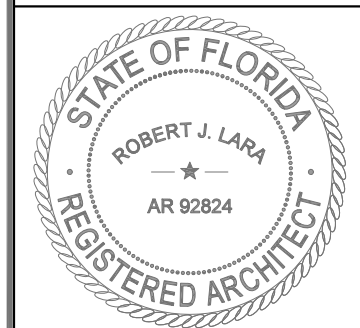

ROBERT JERRY LARA
REGISTERED ARCHITECT
STATE OF FLORIDA
AR92824

5		
4	.	.
3	.	.
2	.	.
1	10/20/14	RE-ISSUED FOR PERMIT
0	09/11/14	ISSUE FOR PERMIT
B	08/12/14	PER CLIENT COMMENTS
A	07/11/14	90% CD SUBMITTAL
No.	Date	Action

Client:

T-Mobile
stick together

1300 CONCORD TERRACE
SUITE 200
SUNRISE, FL. 33323

Consultant:

MORRISON HERSHFIELD
Two South University Drive, Suite 245,
Plantation, FL 33324
Tel: 954.577.4655 Fax: 954.577.4656
FL C OF A #8508
FL Architect business # AA26002368
www.morrisonhershfield.com

Project:

LAKE SIDE PARK
6FB1173B
5555 REGENCY BOULEVARD
COCONUT CREEK, FL 33073

Drawing Title:

ELEVATION

Project No.: 7140041	
Designer: CT	Date: 07/10/14
Drawn By: XL	Checked By: RL
PM Review: LP	Client Approval
Issue No.: 1	Drawing No.: A-4

ELEVATION

24"x36" SCALE: 1/8" = 1'-0"
11"x17" SCALE: 1/16" = 1'-0"
8' 6" 4' 2' 0" 8'

1

SCALE IS BASE ON 22" X 34" D" SIZE

C:\Users\rliaz\AppData\Local\Temp\AcPublish_17552\7140041_6FB1173B_LAKE_SIDE_PARK_L700_MHz_CDs_REV_1_10-20-14.dwg 10/20/2014 3:55pm rliaz

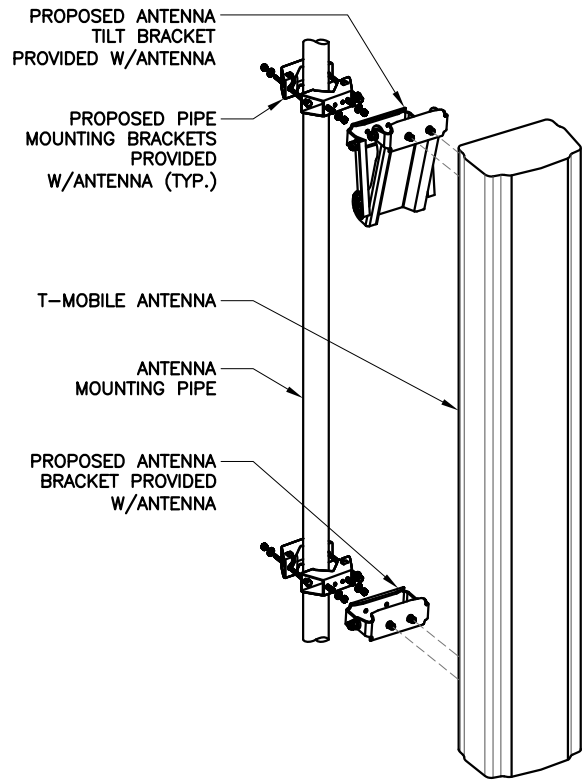

DETAIL REMOVED

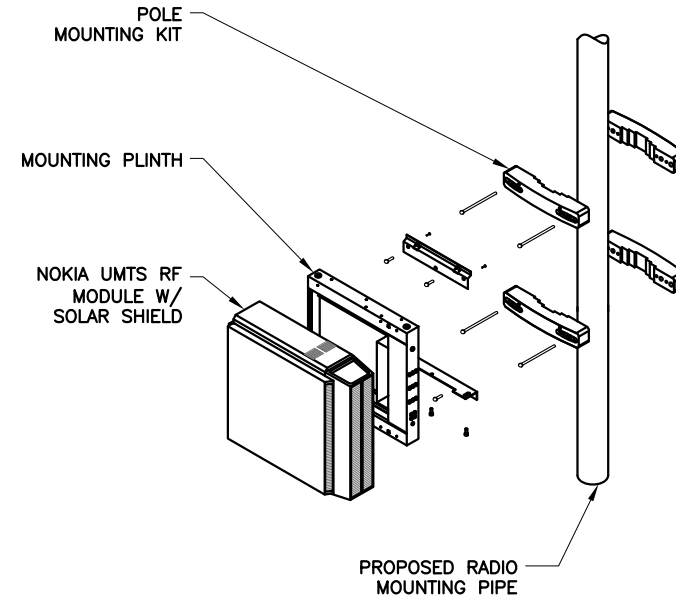

NOTE:
CONNECTING HARDWARE PROVIDED W/ POLE MOUNTING KIT

ANTENNA MOUNTING DETAIL

NTS

1

NOT USED

2

UMTS RRU MOUNTING DETAIL

NTS

3

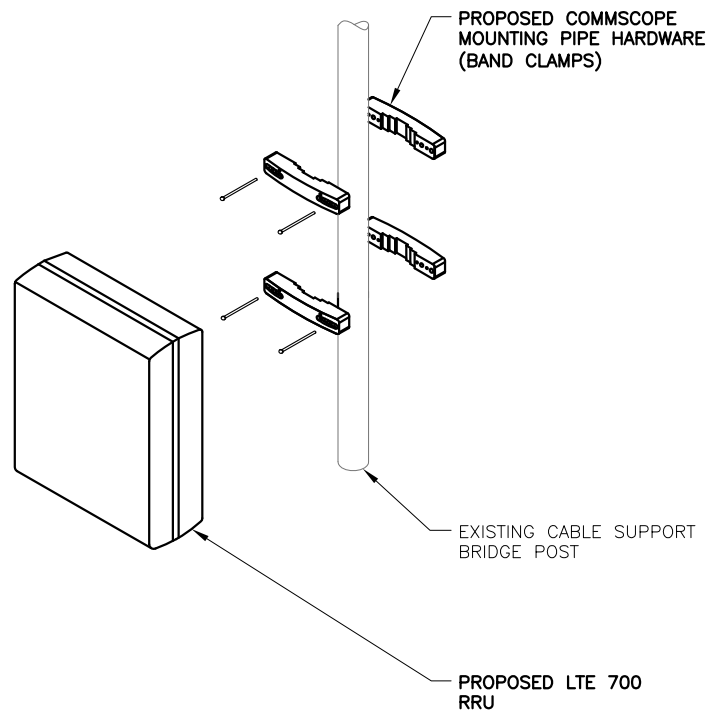

NOTE:
UNIT SHALL BE MOUNTED AS PER MANUFACTURER'S RECOMMENDATIONS.

LTE 700 RRU MOUNTING DETAIL

NTS

4

(NOT USED)

5

(NOT USED)

6

DO NOT SCALE DRAWINGS. CONTRACTOR MUST VERIFY ALL DIMENSIONS AND ADVISE CONSULTANTS OF ANY ERRORS OR OMISSIONS. NO VARIATIONS OR MODIFICATIONS TO WORK SHOWN SHALL BE IMPLEMENTED WITHOUT PRIOR WRITTEN APPROVAL. ALL PREVIOUS ISSUES OF THIS DRAWING ARE SUPERSEDED BY THE LATEST REVISION. ALL DRAWINGS AND SPECIFICATIONS REMAIN THE PROPERTY OF MORRISON HERSHFIELD CORPORATION. NEITHER MORRISON HERSHFIELD NOR THE ARCHITECT WILL BE PROVIDING CONSTRUCTION REVIEW OF THIS PROJECT.

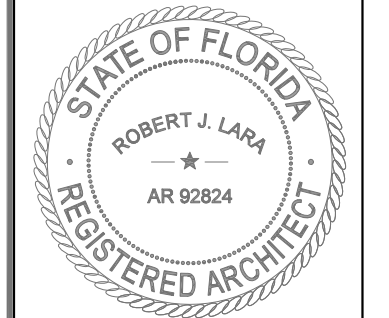

ROBERT JERRY LARA
REGISTERED ARCHITECT
STATE OF FLORIDA
AR92824

5		
4	.	.
3	.	.
2	.	.
1	10/20/14	RE-ISSUED FOR PERMIT
0	09/11/14	ISSUE FOR PERMIT
B	08/12/14	PER CLIENT COMMENTS
A	07/11/14	90% CD SUBMITTAL
No.	Date	Action

Client:

T-Mobile
stick together

1300 CONCORD TERRACE
SUITE 200
SUNRISE, FL 33323

Consultant:

M
MORRISON HERSHFIELD
Two South University Drive, Suite 245,
Plantation, FL 33324
Tel: 954.577.4655 Fax: 954.577.4656
FL C OF A #8508
FL Architect business # AA26002368
www.morrisonhershfield.com

Project:

LAKE SIDE PARK
6FB1173B
5555 REGENCY BOULEVARD
COCONUT CREEK, FL 33073

Drawing Title:

DETAILS

Project No.: 7140041	
Designer: CT	Date: 07/10/14
Drawn By: XL	Checked By: RL
PM Review: LP	Client Approval
Issue No.:	Drawing No.

1

A-5

SCALE IS BASE ON 22" X 34" D SIZE

C:\Users\rliaz\AppData\Local\Temp\AcPublish_17552\7140041_6FB1173B_LAKE_SIDE_PARK_1700_MHz_CDs_REV_1_10-20-14.dwg 10/20/2014 3:55pm rliaz

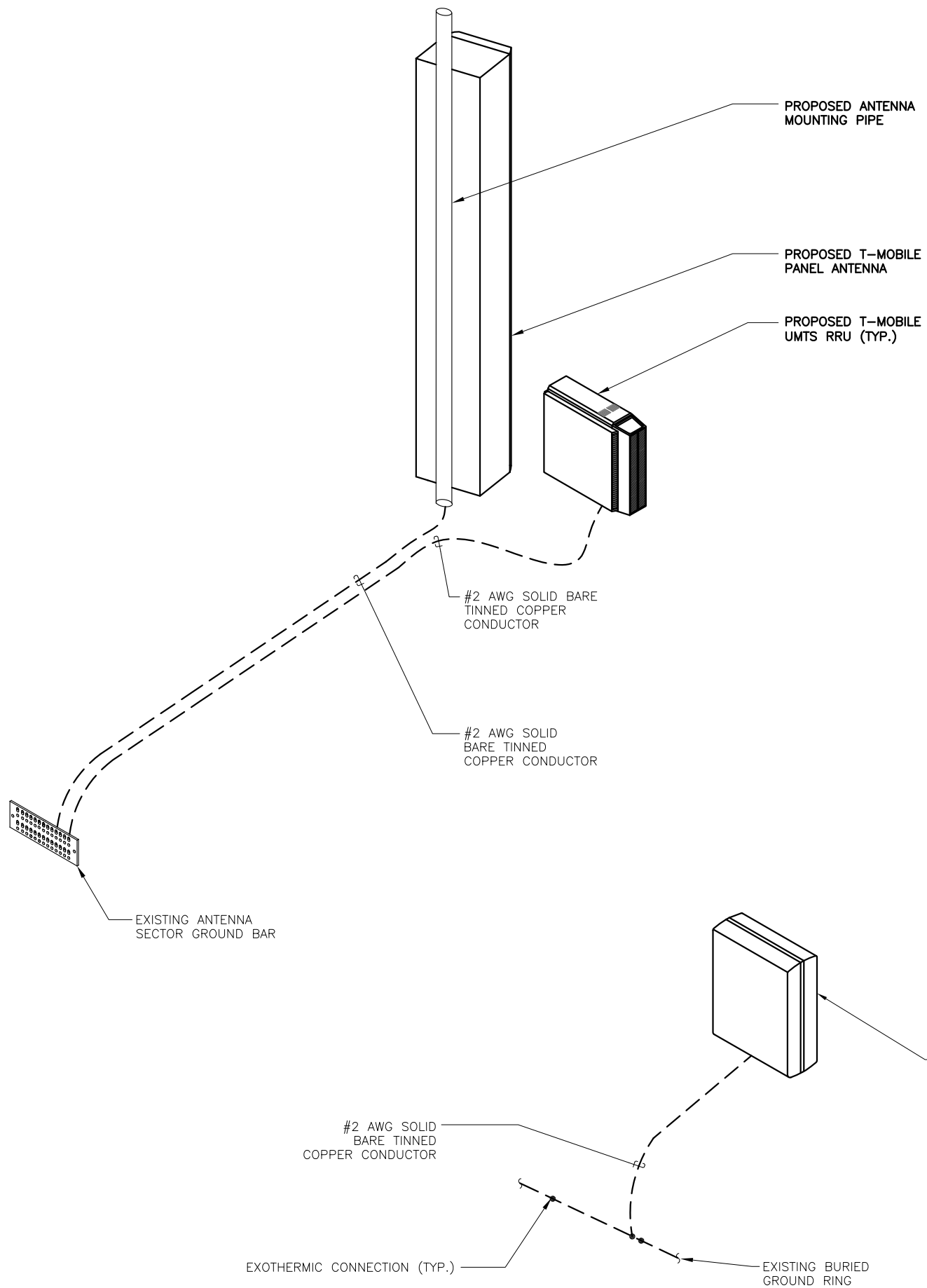

GROUNDING DIAGRAM (TYP.)

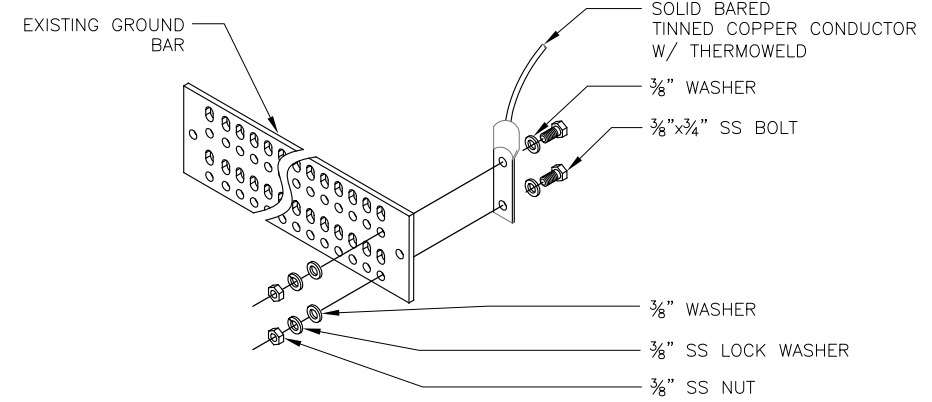

TYPICAL GROUND BAR CONNECTION DETAIL NTS 2

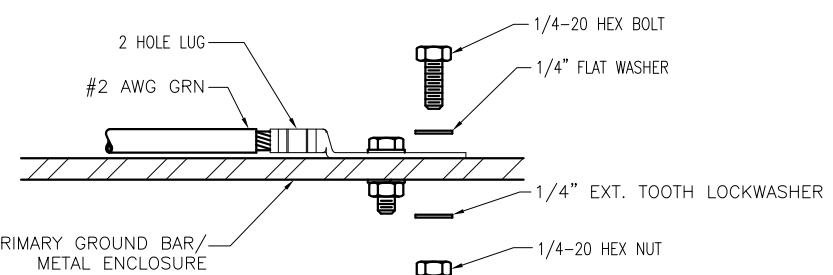

INSTALLATION NOTES:

1. SELECT BOLT LENGTH TO PROVIDE A MINIMUM OF TWO EXPOSED THREADS.
2. BURNISH MOUNTING SURFACE TO REMOVE PAINT IN THE AREA OF LUG CONTACT.
3. APPLY ANTI-OXIDANT COMPOUND TO MATING SURFACE OF LUG AND WIPE CLEAN EXCESS COMPOUND.
4. USE SOLID COPPER WIRE AND MECHANICAL 2-HOLE LUG FOR ALL EXTERIOR GROUNDING.

GROUND CONNECTION DETAIL NTS 3

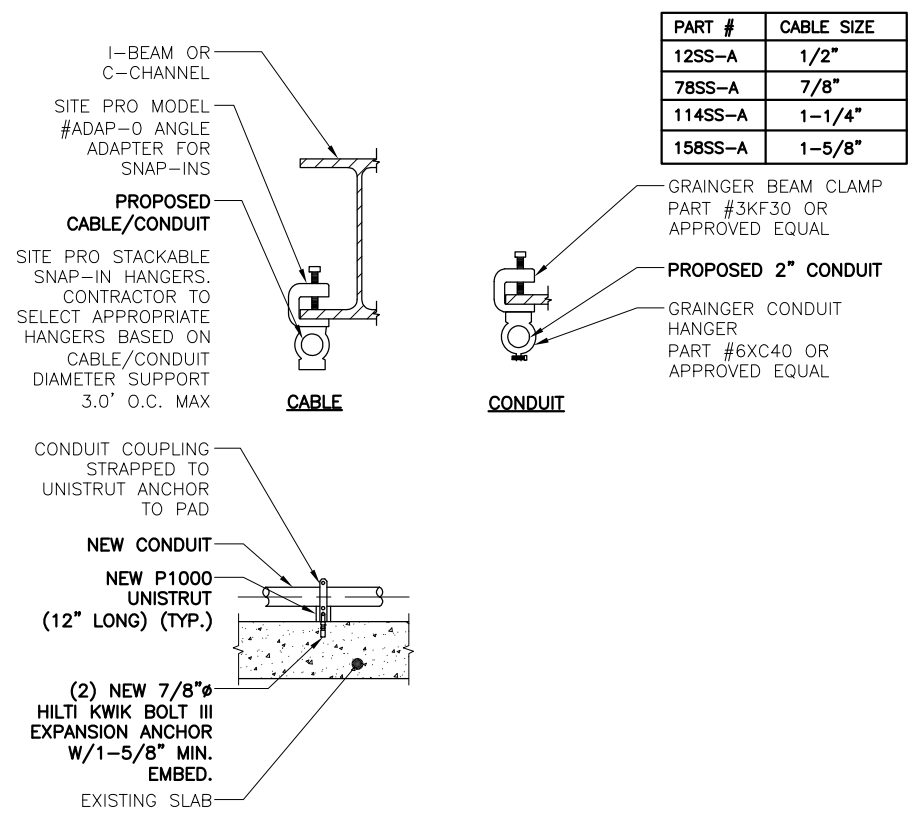

TYPICAL CONDUIT SUPPORT DETAILS NTS 4

DO NOT SCALE DRAWINGS. CONTRACTOR MUST VERIFY ALL DIMENSIONS AND ADVISE CONSULTANTS OF ANY ERRORS OR OMISSIONS. NO VARIATIONS OR MODIFICATIONS TO WORK SHOWN SHALL BE IMPLEMENTED WITHOUT PRIOR WRITTEN APPROVAL. ALL PREVIOUS ISSUES OF THIS DRAWING ARE SUPERSEDED BY THE LATEST REVISION. ALL DRAWINGS AND SPECIFICATIONS REMAIN THE PROPERTY OF MORRISON HERSHFIELD CORPORATION. NEITHER MORRISON HERSHFIELD NOR THE ARCHITECT WILL BE PROVIDING CONSTRUCTION REVIEW OF THIS PROJECT.

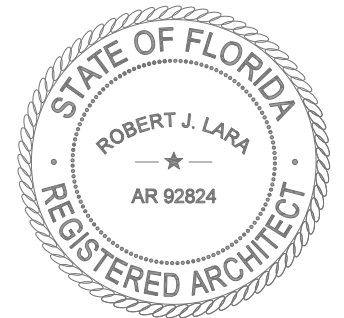

ROBERT JERRY LARA
REGISTERED ARCHITECT
STATE OF FLORIDA
AR92824

5		
4		
3		
2		
1		
0	09/11/14	ISSUE FOR PERMIT
B	08/12/14	PER CLIENT COMMENTS
A	07/11/14	90% CD SUBMITAL
No.	Date	Action

Client:

T-Mobile
stick together

1300 CONCORD TERRACE
SUITE 200
SUNRISE, FL. 33323

Consultant:

MORRISON HERSHFIELD
Two South University Drive, Suite 245,
Plantation, FL 33324
Tel: 954.577.4655 Fax: 954.577.4656
FL C OF A #8508
FL Architect business # AA26002368
www.morrisonhershfield.com

Project:

LAKE SIDE PARK
6FB1173B
5555 REGENCY BOULEVARD
COCONUT CREEK, FL 33073

Drawing Title:
ELECTRICAL AND GROUNDING DETAILS

Project No.: 7140041	
Designer: CT	Date: 07/10/14
Drawn By: XL	Checked By: RL
PM Review: LP	Client Approval
Issue No.: 0	Drawing No.: E-1

SCALE IS BASE ON 22" X 34" D" SIZE