

**TRANSPLANTING NOTES:**  
 TRANSPLANTING OF ALL TREES AND PALMS WILL FOLLOW GOOD HORTICULTURAL PROCEDURES. ALL TREES WILL BE MOVED BY EQUIPMENT OF SUFFICIENT SIZE TO CARRY AND LIFT THE PLANTS AND ROOT BALLS WITHOUT DAMAGE. BACKHOES, LOADERS, CRANES AND TREE SPADES ARE APPROPRIATE.  
 TREES ARE TO BE ROOT PRUNED A MINIMUM OF EIGHT (8) WEEKS BEFORE MOVING. NEW ROOT PRODUCTION MUST BE EVIDENT BEFORE TREES CAN BE MOVED. TRENCHES FOR ROOT PRUNING SHALL BE CUT VERTICALLY TO A DEPTH 6" BELOW THE MAIN BODY OF TREE ROOTS DIRECTLY UNDER THE TRUNK. TRENCHES SHALL BE A MINIMUM OF 8" OR WIDER AS APPROVED BY THE LANDSCAPE ARCHITECT BASED ON THE SIZE OF THE TREE. TRENCH BACKFILL SHALL BE A MIXTURE OF 50/50 OF CLEAN SAND AND NATURAL SOIL WITHOUT DEBRIS OR ROCKS OVER 4" DIAMETER. TREE PROTECTION SHALL BE USED AROUND ALL TREES TO BE MOVED. THE CANOPY OF THESE TREES SHALL NOT BE REDUCED AT TIME OF ROOT PRUNING. ANY STAKING OR BRACING OF THE TREES NECESSARY TO SECURE TREE FROM MOVING DURING THE TIME BEFORE TRANSPLANTING SHALL BE ACCOMPLISHED IMMEDIATELY AFTER ROOT PRUNING. WATERING OF BOTH THE ROOT ZONES AND THE TRENCH AREAS AND THE CANOPY OF THE TREES SHALL BE REQUIRED ON A REGULAR BASIS FOR THE ENTIRE TIME UNTIL ACTUAL MOVING OF THE TREE AND IS PART OF THE CONTRACT. TOTAL APPLIED WATER DURING THIS TIME SHALL BE A MINIMUM OF 2-2 1/2" PER WEEK EXCLUSIVE OF RAINFALL. THE ROOT AREA SHALL BE KEPT MOIST BUT NOT SATURATED. THE CONDITION OF ALL TREES TO BE TRANSPLANTED SHALL BE REVIEWED BY THE LANDSCAPE ARCHITECT ONE WEEK BEFORE ACTUAL MOVING OF THE TREES. HORTICULTURAL CORRECTIONS OR TIME EXTENSIONS MAY BE PLACED ON MOVING THE TREES AT THAT TIME.  
 PREPARATION OF THE NEW HOLES WHERE THE TREES ARE TO BE LOCATED WILL BE SIMILAR TO HOLES FOR NEW TREES AS SHOWN IN PLANTING THE DETAIL.  
 JUST PRIOR TO MOVING THE TREE, THE ROOTBALL SHALL BE EXCAVATED TO THE OUTSIDE OF THE TRENCH TAKING CARE NOT TO DAMAGE THE NEW ROOTS.  
 THE TREE ROOT BALLS SHALL BE WRAPPED IN BURLAP AT ANGLES TO THE BALL'S SURFACE PLANES. ONLY HEMP OR BURLAP TWINE SHALL BE USED TO SECURE THE BURLAPPED WRAPPED BALL. METAL WIRE, MESH OR PLASTIC CORD SHALL NOT BE USED TO SECURE THE BALL. TREES SHALL BE LIFTED BY CLOTH STRAPS AROUND THE ROOT BALL AND IF NECESSARY AROUND THE TREE TRUNK. THE TREE TRUNK AND BALL SHALL BE PROTECTED FROM DAMAGE FROM THE STRAPS BY USE OF PROTECTION LAYERS OF BURLAP. TREES SHALL NOT BE DROPPED DURING ANY PHASE OF THE PRUNING, MOVING OR INSTALLATION PROCESSES OF TRANSPLANTING. TREES SHALL BE STAKED IMMEDIATELY AFTER PLANTING STAKES SHALL BE ADJUSTED AS NECESSARY DURING THE PERIOD OF ESTABLISHMENT TO PREVENT DAMAGE TO THE TREE TRUNK.  
 ALL PLANTING NOTES, SPECIFICATIONS AND ADDITIVES AS SPECIFIED FOR NEW TREES SHALL APPLY TO TRANSPLANTED TREES. THE CONTRACTOR SHALL ALSO BE RESPONSIBLE FOR APPLYING A ROOT STIMULATOR AT 100% RECOMMENDED RATES TO THE NEWLY PLANTED TREES. BACKFILL SOIL SHALL BE AS SPECIFIED FOR NEWLY PLANTED TREES. AFTER PLANTING CONTRACTOR SHALL REMOVE ALL SUCKER BRANCHING AND POOR BRANCHING STRUCTURES. THE CONTRACTOR SHALL ALSO BE RESPONSIBLE FOR WATERING AND CARE OF THE TRANSPLANTED TREES FOR A PERIOD OF 90 DAYS AFTER INSTALLATION OF THE TREES.  
 ALL PERTINENT SPECIFICATIONS, OPERATIONS AND REQUIREMENTS ABOVE SHALL APPLY TO PALMS TO BE TRANSPLANTED EXCEPT AS NEXT NOTED. ALL BACKFILL OF NEW HOLES FOR PALMS SHALL BE CLEAN DEBRIS-FREE SAND WITH NO MORE THAN 30% ORGANIC CONTENT EXCEPT WHERE ORIGINAL SOIL CONDITIONS WARRANT. PALMS SHALL BE PLANTED LEVEL WITH ROOT BALL LEVEL WITH FINISH GRADE UNLESS OTHERWISE APPROVED BY LANDSCAPE ARCHITECT. THE TOP 2" OF THE SAUCER AREA OF A PALM TREE WELL MAY BE TOPSOIL. PALMS SHALL BE TRANSPORTED WITH BALLS BURLAPPED UNLESS PRIOR PERMISSION FROM LANDSCAPE ARCHITECT IS OBTAINED IN WRITING. ALL SABAL PALMS TO BE TRANSPLANTED SHALL BE HURRICANE CUT. ON ALL OTHER PALMS, NO PRUNING OF LIVE, GREEN FRONDS SHALL BE PERMITTED WITHOUT PERMISSION OF THE LANDSCAPE ARCHITECT. NO PRUNING OF FRONDS PAST THE 800 AND 300 POSITION SHALL BE PERMITTED IN ANY CASE.  
 THE CONTRACTOR IS RESPONSIBLE FOR REMOVAL OF ALL TREE WELL BERMS AND STAKING FROM TRANSPLANTED TREES AFTER THE TREES HAVE BEEN ESTABLISHED OR FOR A PERIOD NOT LONGER THAN ONE YEAR AND TO ADJUST OR REPLACE UNDERSTORY PLANTINGS OR SOIL AND REMOVAL TREE WELLS.

© Copyright 2011, Michael J. Petrow and Associates, Inc. All Rights Reserved.

NO	REVISIONS

SCALE:	1"=20'
DATE:	JULY 13, 2010
DRAWN BY:	M.J.P.

**TREE & SHRUB REMOVAL AND RELOCATION PLAN**  
**MERCEDES DEALERSHIP**  
 STATE ROAD 7, COCONUT CREEK, FLORIDA

**Michael J. Petrow and Associates, Inc.**  
 Landscape Architecture  
 P.O. Box 8801, Coral Springs, FL 33075  
 Phone: (954) 466-9659 FL Reg. #382

SHEET NO. T-1  
 OF TWO

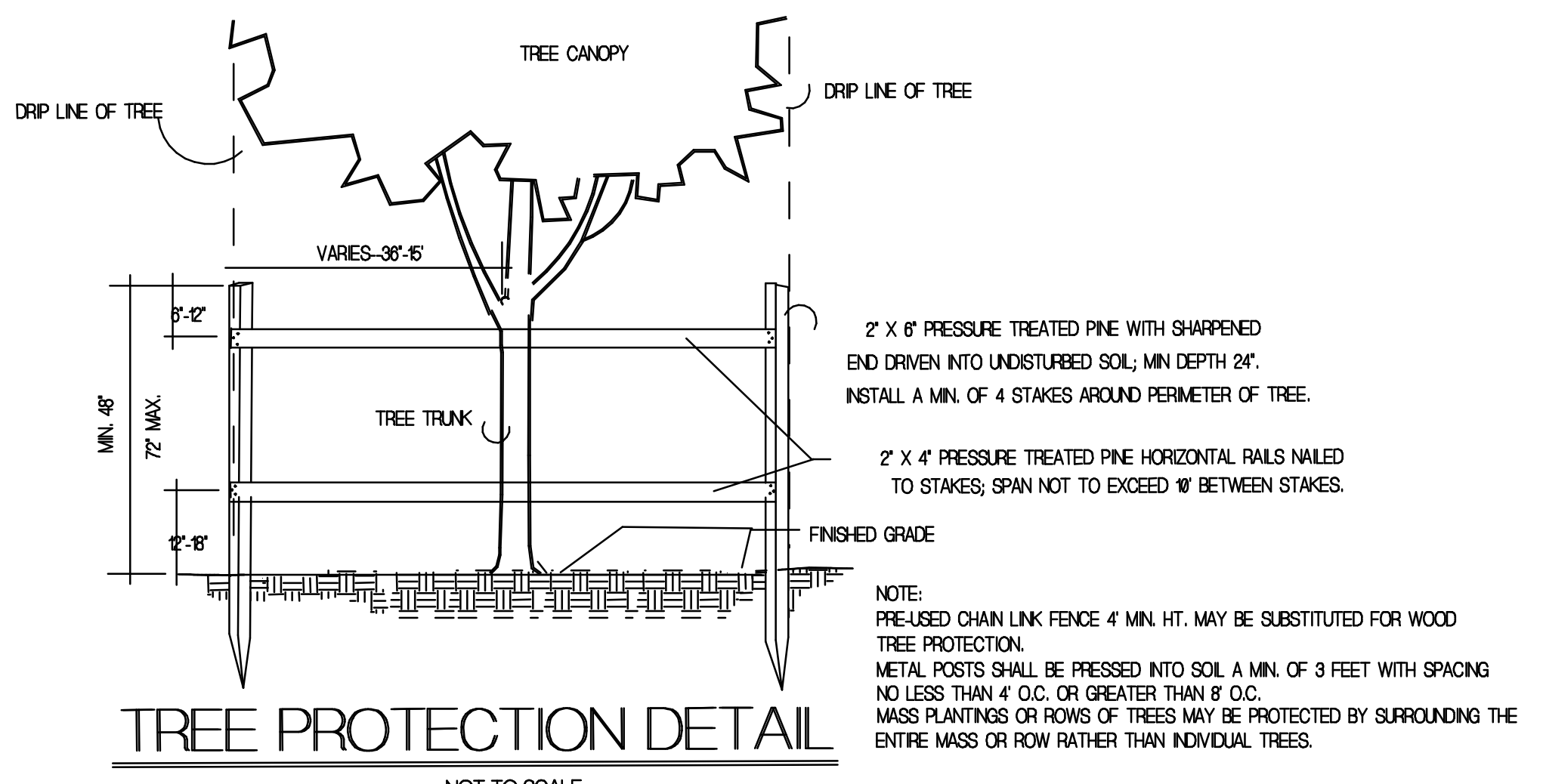

**TREE PROTECTION DETAIL**  
 NOT TO SCALE

NOTES:  
 1. BARRICADES AS SHOWN ON THIS DETAIL FOR EXISTING TREES WITH OVER A 30" DIA. CANOPY, SHALL HAVE THE VERTICAL STAKES PLACED AT LEAST 15' FROM THE TRUNK OF THE TREE.

- RELOCATED PALMS:  
 28 ROYAL PALMS  
 3 TRIPLE ALEXANDER PALMS  
 1 QUEEN PALM
- REMOVED TREES:  
 3 PINK TABEBUIA  
 5 CALLOPHYLLUM  
 12 HIBISCUS TREES  
 4 PYGMY DATE PALMS

THESE DRAWINGS ARE NOT VALID FOR SUBMITTAL OR CONTRACT NEGOTIATION UNLESS SIGNED, SEALED & DATED WITH ORIGINAL SEAL AND EXPIRES 5 YEARS FROM DATE OF ISSUANCE UNLESS OTHERWISE SPECIFIED BY THE LANDSCAPE ARCHITECT. UNSEALED & UNDATED DRAWINGS MAY BE USED FOR CLIENT HOUSE PURPOSES & BIDDING ONLY.