

LEFT SIDE VIEW

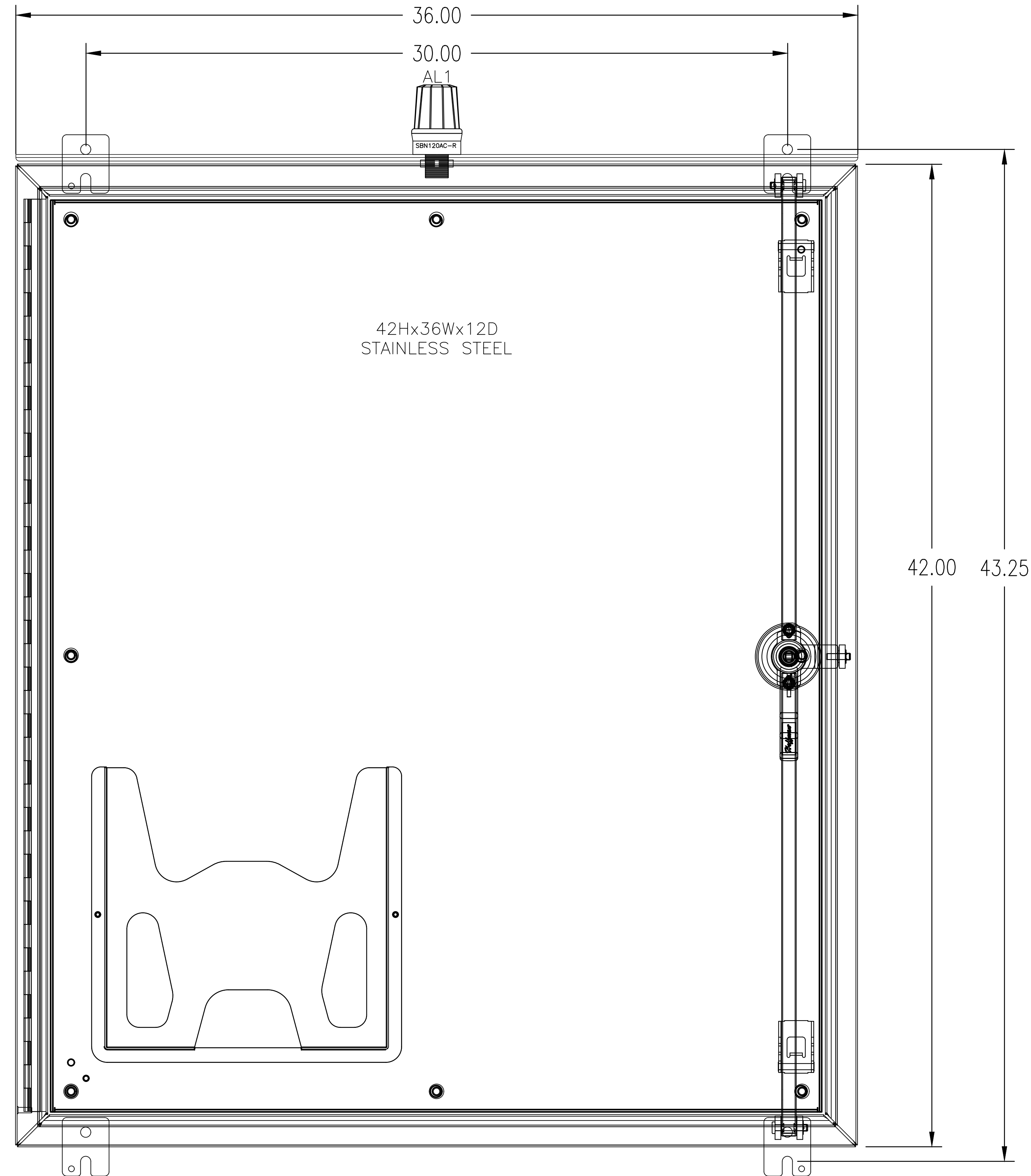

FRONT VIEW

XYLEM PANEL

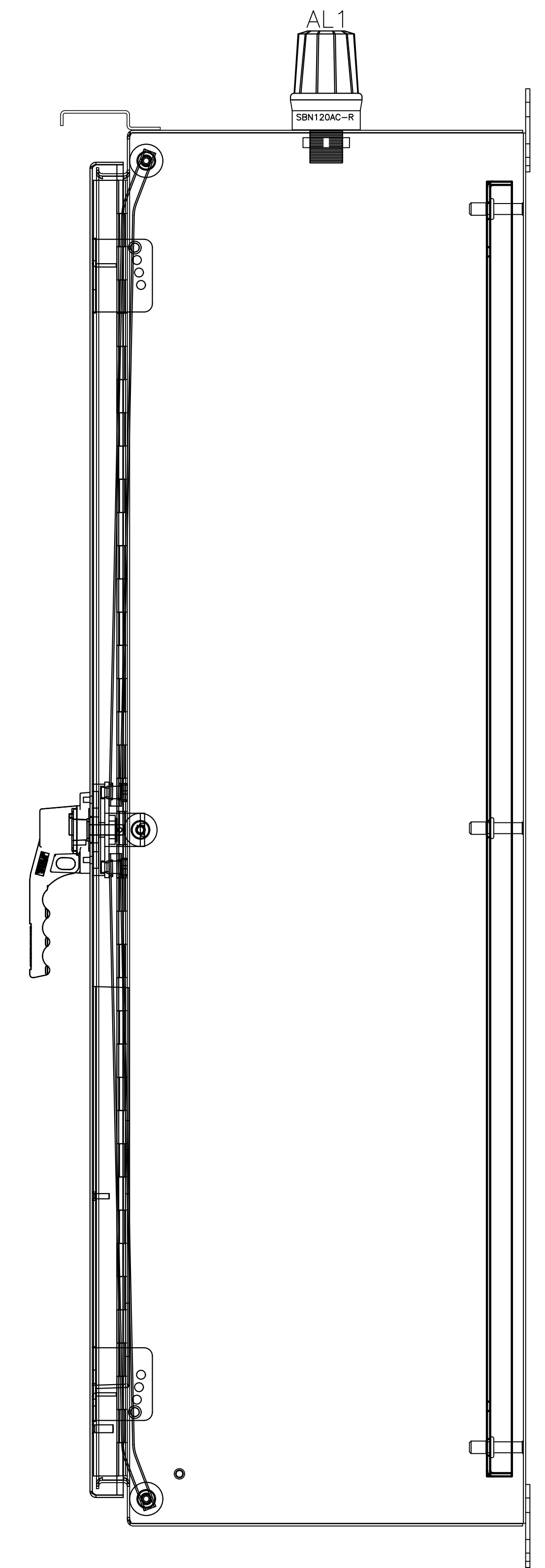

RIGHT SIDE VIEW

- NOTE:
1. SCHEMATIC CONTROL LAYOUT, ELECTRICAL WIRING & PIPING DIAGRAM FOR LIFT STATION ARE SHOWN FOR INFORMATIONAL PURPOSES ONLY. CONTRACTOR SHALL PROVIDE COMPLETE SHOP DRAWING SUBMITTAL OF ENTIRE LIFT STATION, MEETING ALL REQUIREMENTS OF THE CITY OF COCONUT CREEK AND D.E.P. SPECIFICATIONS FOR REVIEW AND APPROVAL PRIOR TO INSTALLATION.
 2. CONTROL PANEL, RTU & ELECTRICAL WIRING IN ACCORDANCE WITH CITY OF COCONUT CREEK SPECIFICATIONS AND PUMP MANUFACTURER
 3. ELECTRICAL SYSTEMS AND COMPONENTS IN RAW WASTEWATER WET WELLS SHALL COMPLY WITH THE NATIONAL CODE REQUIREMENTS FOR CLASS 1, DIVISION 1, GROUP D LOCATIONS.
 4. ALL WORK SHALL COMPLY WITH NATIONAL ELECTRIC CODE AND LOCAL CODES.
 5. CONTROL PANEL SHALL BE UL LISTED AND SHALL COMPLY WITH ARTICLE 409 OF THE NEC.
 6. ALL ABOVE GROUND PANELS, ELECTRICAL EQUIPMENT AND APPURTENANCES SHALL BE CERTIFIED PER FLORIDA BUILDING CODE. CONTRACTOR TO PROVIDE SIGNED AND SEALED WIND LOAD CALCULATIONS FROM LICENSED ENGINEER IN THE STATE OF FLORIDA.
 7. PUMP MANUFACTURER SHALL BE RESPONSIBLE FOR THE SUPPLY OF PUMP AND ELECTRIC CONTROL PANEL.

FILE: K:\PROJECTS\15-xxx\15-3715\dwg\3715e.dwg
 PLOT DATE: 1/20/2016 4:20 PM BY: Andy Venneman
 LAYOUT: [C-4.7]

NO.	DATE	DESCRIPTION

MIDTOWN RESIDENCES
 @ COCONUT CREEK
 COCONUT CREEK, FLORIDA
 LIFT STATION PLAN & DETAILS

DATE:
 Aug. 2015

SCALE:
 N.T.S.

DESIGNED BY:
 C.R.L.

DRAWN BY:
 A.E.V.

JOB NUMBER
 15-3715

SHEET No.
 C-4.7

SEAL
 Jan 20 2016
 CLIFFORD R. LOUTAN, P.E.
 FL. REG. NO. 56890

Sun-Tech Engineering, Inc.
 Engineers - Planners - Surveyors
 1600 West Oakland Park Boulevard
 Ft. Lauderdale, FL 33311
 www.suntecheng.com
 Certificate of Auth. # 7097
 Phone (954)777-3123
 Fax (954)777-3114