

NO.	DATE	DESCRIPTION

**MIDTOWN RESIDENCES
 @ COCONUT CREEK
 FLORIDA
 STORMWATER POLLUTION
 PREVENTION DETAIL**

DATE:
Jul. 2015

SCALE:
N.T.S.

DESIGNED BY:
C.R.L.

DRAWN BY:
A.E.V.

JOB NUMBER
15-3715

SHEET No.
C-5.3

SEAL

Jan 20 2016
 CLIFFORD R. LOUTAN, P.E.
 FL. REG. NO. 56890

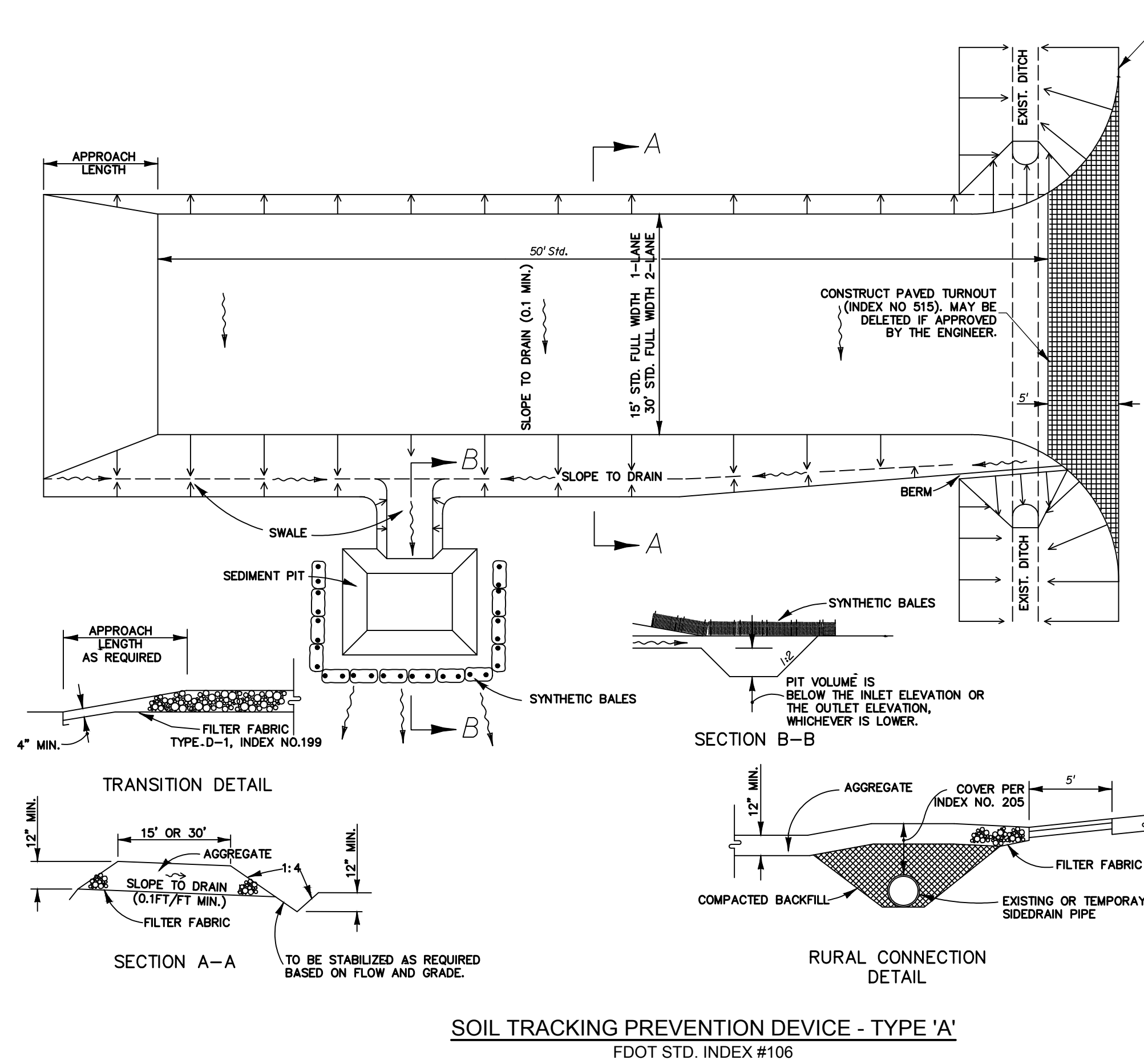

- GENERAL NOTES**
- A SOIL TRACKING PREVENTION DEVICE (S.T.P.D.) SHALL BE CONSTRUCTED AT ALL LOCATIONS DESIGNATED BY THE ENGINEER FOR POINTS OF EGRESS FROM UNSTABILIZED AREAS OF THE PROJECT TO PUBLIC ROADS WHERE OFFSITE TRACKING OF MUD COULD OCCUR. TRAFFIC FROM UNSTABILIZED AREAS OF THE CONSTRUCTION PROJECT SHALL BE DIRECTED THRU A S.T.P.D. BARRIERS, FLAGGING, OR OTHER POSITIVE MEANS SHALL BE USED AS REQUIRED TO LIMIT AND DIRECT VEHICULAR EGRESS ACROSS THE S.T.P.D.
 - THE CONTRACTOR MAY PROPOSE AN ALTERNATIVE TECHNIQUE TO MINIMIZE OFFSITE TRACKING OF SEDIMENT. THE ALTERNATIVE MUST BE REVIEWED AND APPROVED BY THE ENGINEER APPROVED TO ITS USE.
 - ALL MATERIALS SPILLED, DROPPED OR TRACKED ONTO PUBLIC ROADS (INCLUDING THE S.T.P.D. AGGREGATE AND CONSTRUCTION MUD) SHALL BE REMOVED DAILY, OR MORE FREQUENTLY IF SO DIRECTED BY THE ENGINEER.
 - AGGREGATES SHALL BE AS DESCRIBED IN SECTION 901 EXCLUDING 901-2.3. AGGREGATES SHALL BE FOOT SIZE #1. IF THIS SIZE IS NOT AVAILABLE, THE NEXT AVAILABLE SMALLER SIZE AGGREGATE MAY BE SUBSTITUTED WITH THE APPROVAL OF THE ENGINEER. SIZES CONTAINING EXCESSIVE SMALL AGGREGATE WILL TRACK OFF THE PROJECT AND ARE UNSUITABLE.
 - THE SEDIMENT PIT SHOULD PROVIDE A RETENTION VOLUME OF 3600 CUBIC FEET/ACRE OF SURFACE AREA DRAINING TO THE PIT. WHEN THE S.T.P.D. IS ISOLATED FROM OTHER DRAINAGE AREAS, THE FOLLOWING PIT VOLUMES WILL SATISFY THIS REQUIREMENT:
 15'x50'=100 FT³ 30'x50'=200 FT³
 AS AN OPTION TO THE SEDIMENT PIT, THE WIDTH OF THE SWALE BOTTOM CAN BE INCREASED TO OBTAIN THE VOLUME. WHEN THE SEDIMENT PIT OR SWALE VOLUME HAS BEEN REDUCED TO ONE HALF, IT SHALL BE CLEANED. WHEN A SWALE IS USED, SYNTHETIC BALES OR SILT FENCE SHALL BE PLACED ALONG THE ENTIRE LENGTH.
 - THE SWALE DITCH DRAINING THE S.T.P.D. SHALL HAVE A 0.2% MINIMUM AND A 1.0% MAXIMUM GRADE ALONG THE S.T.P.D. AND TO THE SEDIMENT PIT.
 - MITERED END SECTIONS ARE NOT REQUIRED WHEN THE SIDE DRAIN PIPE SATISFIES THE CLEAR ZONE REQUIREMENTS.
 - THE S.T.P.D. SHALL BE MAINTAINED IN A CONDITION THAT WILL ALLOW IT TO PERFORM ITS FUNCTION. TO PREVENT OFFSITE TRACKING, THE S.T.P.D. SHALL BE RINSED (DAILY WHEN IN USE) TO MOVE ACCUMULATED MUD DOWNWARD THRU THE STONE. ADDITIONAL STABILIZATION OF THE VEHICULAR ROUTE LEADING TO THE S.T.P.D. MAY BE REQUIRED TO LIMIT THE MUD TRACKED.
 - A S.T.P.D. SHALL BE PAID FOR UNDER THE CONTRACT UNIT PRICE FOR SOIL TRACKING PREVENTION DEVICE, EA. THE UNIT PRICE SHALL CONSTITUTE FULL COMPENSATION FOR CONSTRUCTION, MAINTENANCE, REPLACEMENT OF MATERIALS, REMOVAL AND RESTORATION OF THE AREA UTILIZED FOR THE S.T.P.D.; INCLUDING BUT NOT LIMITED TO EXCAVATION, GRADING, TEMPORARY PIPE (INCLUDING M.E.S. WHEN REQUIRED), FILTER FABRIC, AGGREGATE, PAVED TURNOUT (INCLUDING ASPHALT AND BASE CONSTRUCTION), DITCH STABILIZATION, APPROACH ROUTE STABILIZATION, SEDIMENT REMOVAL AND DISPOSAL, WATER RINSING AND CLEANING OF THE S.T.P.D. AND CLEANING OF PUBLIC ROADS, GRASSING AND SOD. SYNTHETIC BALES OR BALE TYPE BARRIER SHALL BE PAID FOR UNDER THE CONTRACT UNIT PRICE FOR SYNTHETIC HAY BALES. IF SILT FENCE SHALL BE PAID FOR UNDER THE CONTRACT UNIT PRICE FOR STAKED SILT FENCE, LF.
 - THE NOMINAL SIZE OF A STANDARD S.T.P.D. IS 15'x50' UNLESS OTHERWISE SHOWN IN THE PLANS. IF THE VOLUME OF ENTERING AND EXITING VEHICLES WARRANT, A 30' WIDTH S.T.P.D. MAY BE USED IF APPROVED BY THE ENGINEER. WHEN A DOUBLE WIDTH (30') S.T.P.D. IS USED, THE PAY QUANTITY SHALL BE 2 FOR EACH LOCATION.

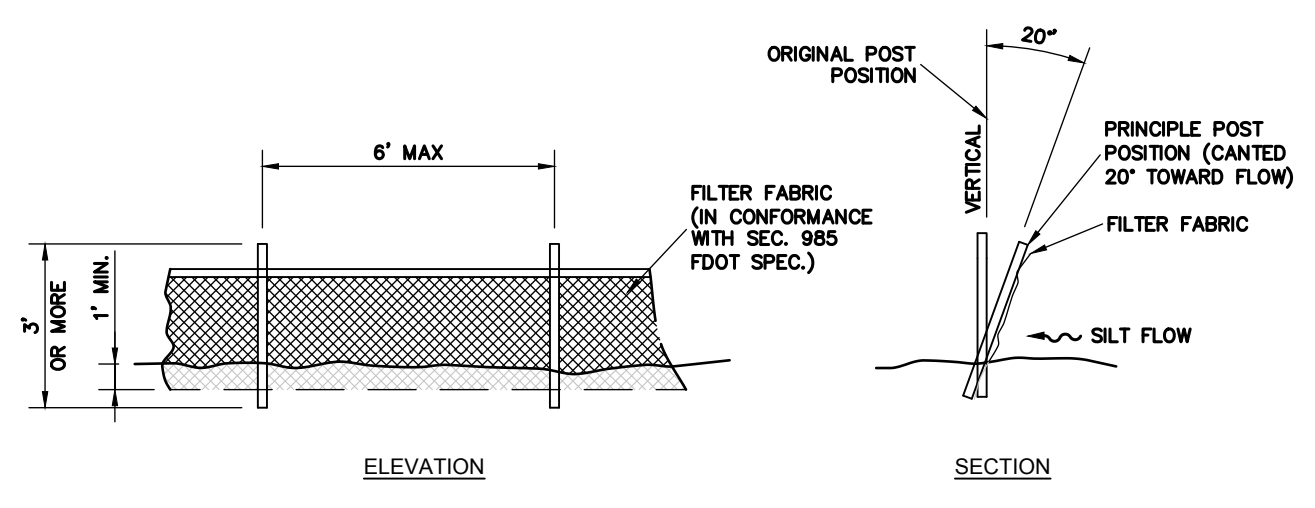

SILT FENCE DETAIL