

**G, H**

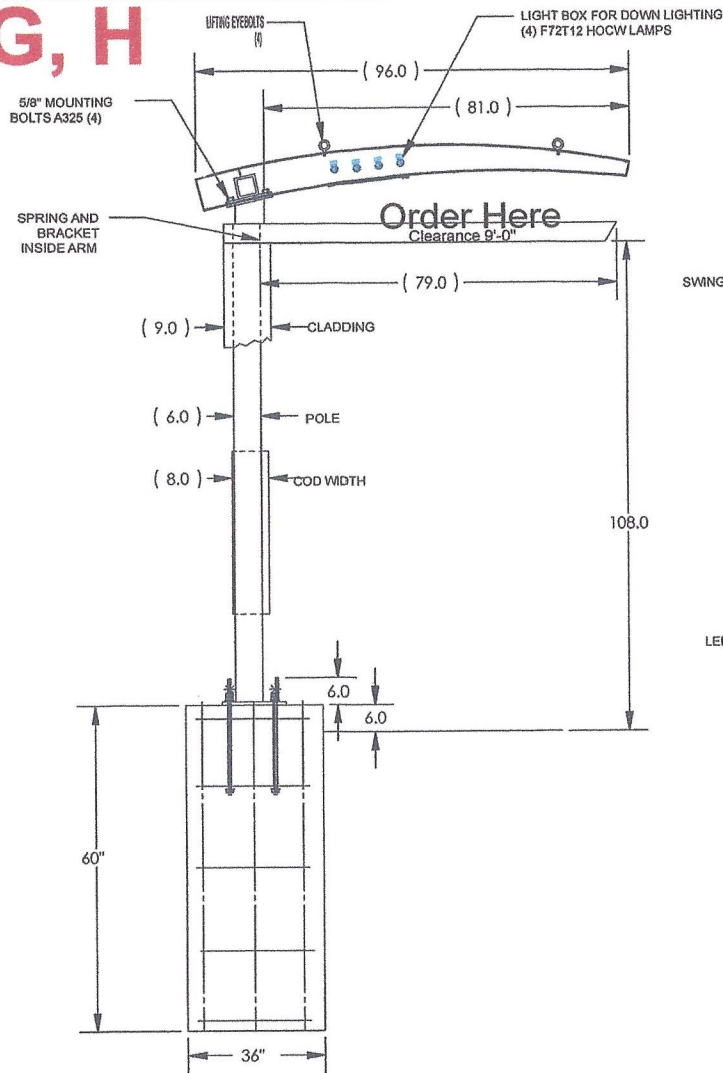

**Order Here**  
Clearance 9'-0"

**WIND LOAD CRITERIA:** 2010 F.B.C., 160 MPH Ultimate wind speed - exposure "D" Risk Category 1 Per ASCE 7-10. All fasteners and other metal in contact with aluminum shall be stainless steel or hot dip galv.

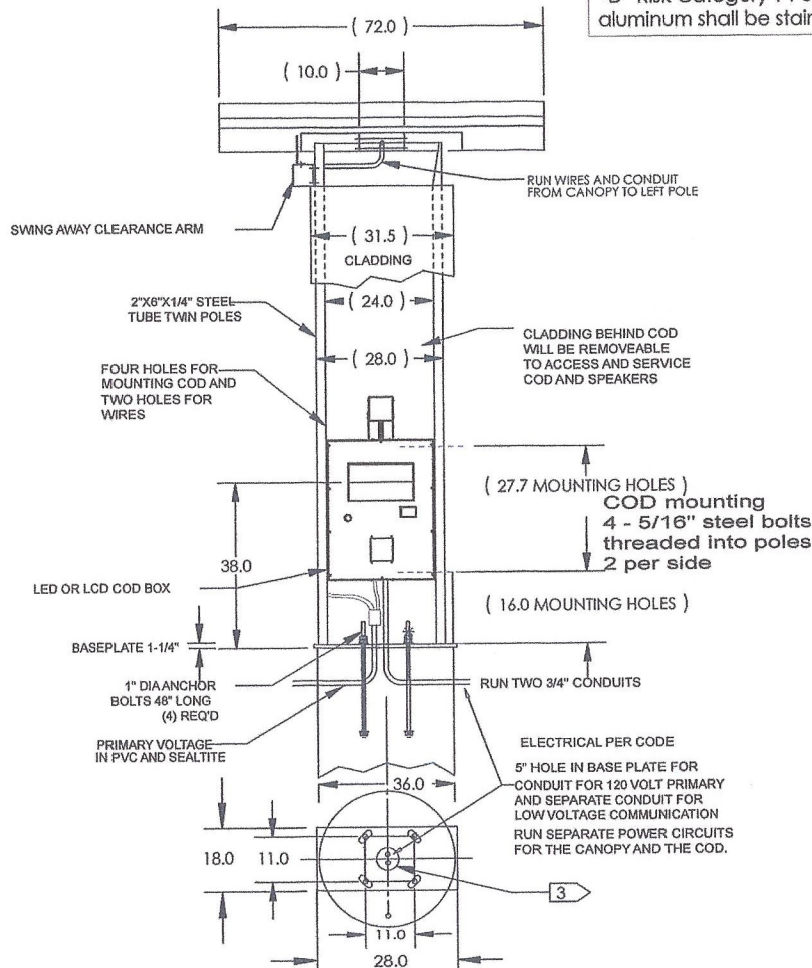

- INSTALLER INSTRUCTIONS:**
1. STAKE FOUNDATION AREA AND CONFIRM FINAL GRADE REQUIREMENTS WITH G. C.
  2. EXCAVATE FOUNDATION AREA.
  3. INSTALL CONDUIT STUB AND ANCHOR BOLTS AND POUR CONCRETE. (PRIMARY ELECTRICAL SERVICE TO BASE BY G. C.) NOTE: COMBINED CONDUIT SHOULD NOT EXCEED 5 INCHES IN DIAMETER.
  4. ALLOW CONCRETE CURE TIME AS REQUIRED.
  5. INSTALL POLE ENSURE POLE IS LEVELED.
  6. MOUNT CANOPY ON POLE.
  7. INSTALL "ORDER HERE" ARM TO POLE, LEVEL.
  8. MAKE FINAL ELECTRICAL HOOK UP TO PRIMARY IN WEATHER PROOF JUNCTION BOX SUPPLIED BY INSTALLER (ALL ELECTRICAL TO MEET ALL LOCAL CODES).
  9. IF THERE IS A COD, MAKE ELECTRICAL AND POS CONNECTIONS.
  10. ATTACH CLADDING TO POLE PER INSTRUCTIONS WITH CLADDING.
  11. NOTE: POLE SUPPLIED WITH POWDER-COAT PAINTED FINISH. INSTALLER TO PERFORM TOUCH-UP PAINTING AS REQUIRED. PAINT WILL BE SHIPPED WITH THE POLE FOR THIS PURPOSE.
  12. TEST LIGHT CANOPY AND TOUCH UP FRAME AS NEEDED.
  13. REMOVE LIFTING BOLTS AND REINSTALL HEX BOLTS.
  14. CLEAN UP AREA AND REMOVE ANY PACKING MATL.

- DESIGN NOTES:**
- 1.) ALL CONCRETE EXCEPT CONCRETE USED FOR BACK FILL SHALL DEVELOP A MINIMUM COMPRESSIVE STRENGTH OF 3000 P.S.I
  - 2.) CONCRETE BASE DESIGNED USING GOOD TO AVERAGE SOILS HAVING AN ALLOWABLE BEARING CAPACITY OF 200 P.S.F.F.T.
  - 3.) ALL FOOTING EXCAVATIONS ARE TO BE FREE OF WATER AND FOREIGN MATTER BEFORE PLACING CONCRETE.
  - 4.) IF THESE CONDITIONS DO NOT EXIST, A NEW BASE MUST BE DESIGNED BY A LICENSED STRUCTURAL ENGINEER.

**ELECTRICAL DATA:**  
LINELOAD: 3.64 AMPS (1) 20 AMP 120 VOLT CIRCUIT ENCLOSED BALLAST FULHAM WORKHORSE 7 LAMPS: F72T12 CW/HO (4) REQ'D

**AUGER TYPE FOOTING**  
USE SIX #5 VERTICAL BARS WITH #3 TIE BARS 12" ON CENTER  
**ELECTRICAL NOTES ILLUMINATED CABINETS**

Primary wire size - #12 THWN  
Disconnect switch - at base of sign, 20 amp single pole, timeclock at panel room  
Maximum load - 16 amps 120 volts per circuit maximum circuit size 20 amps per NEC 600-6A  
Ballast - Universal H.O. or equiv.  
Lamps - G.E. High output daylight or equiv. sizes vary with cabinet dimensions  
Sockets - Kulka 5843 H.O. or equiv.  
Conduit - minimum 1/2"  
Total sign load - 3.64 amps 120 volts  
Total sign circuits - 1  
All components shall be U.L. approved, and sign unit complete shall have a UL listing sticker.  
Ballasts shall have independent U.L. approval (fused where required)  
All installations shall be in compliance with N.E.C. and state, county, or local codes  
All signs shall be bonded to building equipment bonding conductor per N.E.C. 250

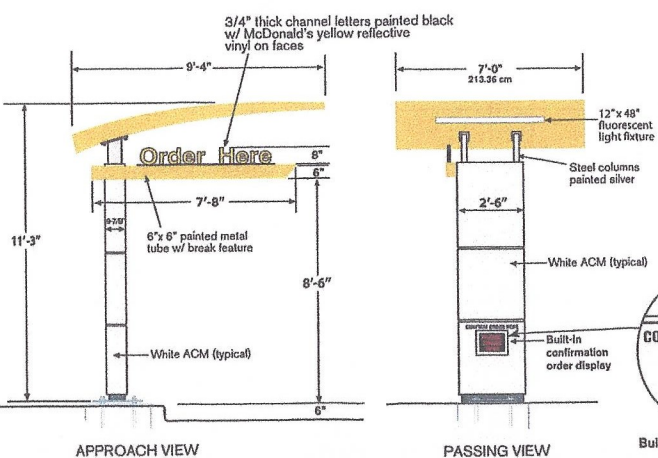

**Illumination:** 4 - F72T12 CW/HO  
**Electrical:** 15 Amp 120 Volt  
**Ballast:** Fulham Workhorse 7  
**Ship Weight:** 1300 lbs.  
**Other:**



Illuminated awning provides a customer safe environment at night and protection from inclement weather

**McDonald's**  
Coconut Creek  
4200 W. Sample Blvd.  
Coconut Creek, FL.

**Kemp Signs inc.**  
1767 Hill Ave.  
West Palm Beach, Fl. 33407  
561-840-6382 fax 561-840-6385

**ALBERT A. GARGIULO, P.E.**  
CONSULTING ENGINEER  
Lic. No. PE 32582  
324 SUNSET RD.  
WEST PALM BEACH, FL. 33401  
561-686-5554

*Albert A. Gargiulo*  
1/16/2012